

THE FUTURE OF 9-1-1: NEW TECHNOLOGIES AND THE NEED FOR REFORM

PHILIP J. WEISER,* DALE HATFIELD,** & BRAD BERNTHAL***

INTRODUCTION.....	215
I. THE HISTORY AND BACKGROUND OF 9-1-1	218
II. THE TECHNOLOGY OF THE 9-1-1 NETWORK	223
A. <i>Introduction</i>	223
B. <i>Background and Evolution of Our Nation's 9-1-1 System</i>	225
C. <i>Adapting the 9-1-1 Network to Allow Wireless and VoIP Calls</i>	231
D. <i>Constraints and Shortcomings Associated with the Current 9-1-1 System</i>	236
1. Constraints on Serving and/or Exploiting Modern End-User Devices	236
2. Constraints Associated with Analog Circuit Switching and Selective Routers	239
3. Constraints Associated with In-band Multi-frequency CAMA Signaling	241
4. Constraints Associated with Fixed Point-to-Point Data Links	243
E. <i>Elements and Architecture of the Next Generation 9-1-1 System</i>	243
1. Introduction to Next Generation Technology and Its Application to 9-1-1	244
2. The Case for a Next Generation Architecture for E9-1-1	247

* Professor of Law and Telecommunications at the University of Colorado Law School. This Article stems from a report commissioned by the 9-1-1 Industry Alliance ("9IA"). It resulted from a series of interviews as well as independent research. The content and conclusions of this Article (as well as the earlier report upon which it was based) reflect the authors' perspective alone and should not be attributed to 9IA or any of its members. This Article benefited greatly from valuable research from Valerie Yates, Steve Robertson, Mark Changaris, and Brian Geoghegan.

** Adjunct Professor, Interdisciplinary Telecommunications Program, University of Colorado.

*** Associate Clinical Professor, University of Colorado Law School.

III. TOWARD NEW GOVERNANCE MODELS FOR E9-1-1	251
A. <i>Background</i>	252
B. <i>The Range of Governance Models</i>	253
C. <i>Recommended Governance Reforms within State 9-1-1 Management</i>	255
1. The Importance of an Empowered Oversight Body	255
2. Statewide Oversight over Mission Critical Networks	256
3. An Incentive Strategy for PSAP Technology Upgrades	258
4. An Empowerment Strategy toward PSAP Cooperation....	261
D. <i>The Role for the Federal Government</i>	263
IV. THE NEED FOR A NEW FUNDING STRATEGY	265
A. <i>The Importance of Understanding That 9-1-1 Is a Public Good and Innovation Should Be Promoted</i>	267
B. <i>The Current System of Collecting, Remitting, Allocating, and Using 9-1-1 Funds</i>	271
1. 9-1-1 Fund Collection.....	272
2. Remittance of 9-1-1 Funds	274
3. Allocation of 9-1-1 Funds	275
4. Usage of 9-1-1 Funds	277
C. <i>Five Policy Recommendations for 9-1-1 Funding Going Forward</i>	281
1. 9-1-1 Services Must Be Better Aligned with the Expectations and Demands of Consumers and Citizens....	281
2. Responsible Policymakers Must Have a Viable Funding Strategy for Achieving Next Generation 9-1-1	282
3. The Public Good Nature of 9-1-1 Today Suggests That 9-1-1 Funding Models Should Be Augmented by Financing That Facilitate Capital Expenditures	285
4. Greater Oversight Should Be Used to Monitor Fund Collection, Deter 9-1-1 Funding Raids, and Ensure That 9-1-1 Purchases Reflect Sound Judgment	287
5. 9-1-1 Surcharges Should Be Assessed in a Principled Manner That Promotes Competition	291
CONCLUSION.....	291

INTRODUCTION

The development of the United States' 9-1-1 system remains a public policy success story. This success masks, however, the system's vulnerabilities and its failure to keep up with technological change. In particular, our 9-1-1 system was not designed for a world of dynamic technologies such as Voice over Internet Protocol ("VoIP"). To update our 9-1-1 system for today's communications marketplace thus requires changes in technology, governance, and funding strategies.

Many citizens do not realize that our 9-1-1 system is only two generations old. In 1968, at the outset of the effort to establish 9-1-1 as the emergency number in the United States, *Life* magazine observed, "It won't be long before 911 takes over as the most memorable trio of digits in American culture."¹ Today, this is largely the case. Wherever an individual needs help, a call to 9-1-1 almost always goes through and, in many cases, also reports the caller's telephone number and location to the 9-1-1 operator. Notably, an estimated 99 percent of the population and 96 percent of the geographic United States have access to at least basic 9-1-1 services.² Most importantly, the success of our 9-1-1 system has saved numerous lives. Due to the system's success over the past four decades, American citizens now reasonably expect access to 9-1-1 as a critical public service that is ubiquitous and reliable.

The 9-1-1 system's success to date belies the fact that its core premises will not continue to serve it effectively and it has come to a critical juncture. In particular, the balkanized nature of 9-1-1 systems that differ across jurisdictions and are supported by Byzantine funding mechanisms obscure a simple but profound development: our nation's emergency communications system is not keeping up with or taking advantage of technological change. The original provision of 9-1-1 arose in a world where a single carrier (AT&T in most cases) provided service to customers using analog voice connections from fixed locations. Today, by contrast, there are a multiplicity of providers, almost all of which use digital technology and many of which offer "nomadic" or mobile services. In response to technological innovation, our current 9-1-1 infrastructure is a clever but "jury-rigged" system that uses yesterday's technology to provide service in a world very different than that for which it was designed. Indeed, the limits of the legacy technology used

1. Letter from Lee Loevinger, Def. Comm'r, FCC, to Hon. Joseph A. Califano, Jr., Special Assistant to the President, The White House Office (Mar. 7, 1968) (on file at the Lyndon Baines Johnson Library and Museum), *available at* http://www.911dispatch.com/911/history/loevinger_letter1.html.

2. E9-1-1 Institute, The Issues, <http://www.e911institute.org/theIssues/index.html> (last visited May 10, 2008).

in emergency communications can be best understood by viewing today's 9-1-1 system as an analog island in a digital sea. To be sure, the ingenuity of the engineers who have stretched the current system to accommodate wireless telephony and other services is admirable. But policymakers must recognize that the system is stretched to its limits and change is required.

In the telecommunications industry overall, competitive forces and technological innovations have ushered in an era of digital, mobile, and often Internet Protocol-based communications capabilities. At the same time, limited competition in portions of the 9-1-1 system and analog bottlenecks have conspired to restrain the capabilities of today's 9-1-1 systems. Because the system continues to work and policymakers largely do not appreciate the system's technological limitations, decision makers not only fail to focus on this challenge, but instead are all too willing to raid 9-1-1 funds to put them to other uses. Accordingly, our emergency communications networks are unable to accommodate what is increasingly viewed as basic functionality inherent in many of today's advanced technologies. These include, for example, the ability to receive photos from a scene or the ability to receive text messages, as students attempting to text message 9-1-1 during the recent Virginia Tech tragedy realized when their messages did not go through. This chasm between the capabilities of modern networks and today's 9-1-1 system needs to be bridged. Put differently, it is a grave policy failure that, compared to state-of-the-art commercial networks, our emergency communications networks are less efficient, less technologically advanced, and, as a consequence, less able to provide the public with the level of protection it deserves.³

This Article sets forth a coherent vision for reforming the state of 9-1-1 services. Notably, the United States' 9-1-1 "system" is hardly a monolith and prescriptions for its evolution cannot be reduced to simple "one size fits all" solutions. In practice, the system is comprised of numerous jurisdictions (including over 6000 Public Safety Answering Points ("PSAPs")); a myriad of governance structures and controls which vary across state, county, and local jurisdictions; a ballooning number of service providers; and a diversity of funding amounts and models that differ across jurisdictional boundaries. The result, not surprisingly, is a fractured and complicated system where policy is highly contingent on

3. As a New York Times article observed: the 9-1-1 "system has not kept pace with the nation's rapidly changing communication habits. As it ages, it is cracking, with problems like system overload, understaffing, misrouted calls and bug-ridden databases leading to unanswered calls and dangerous errors." Shaila Dewan, *An SOS for 911 Systems in an Age of High-Tech*, N.Y. TIMES, Apr. 6, 2007, at A1.

parochial and often political perspectives.⁴

Even with such a wide ambit of variability, however, it is important for policymakers to appreciate the basic weaknesses of our current system of 9-1-1 and the clear directions for reform. Accordingly, with this goal in mind, this Article serves as a compendium that integrates technology, governance, and funding perspectives into a comprehensive call for reform. By so doing, we hope that this Article will draw attention to the importance of coordinated decision making and improved funding models in upgrading the state of 9-1-1 system capabilities in the United States.

In developing our recommendations, we conducted a thorough research effort that involved reaching out to a large number of stakeholders, ranging from public safety answering points to state regulatory commissions to affected companies.⁵ Additionally, we canvassed relevant government reports and audits, industry publications and materials, secondary literature, and technical materials. In total, our research pointed clearly to a number of best practices and suggestions. Stated simply, the essence of our recommendations is that: (1) clear leadership and vision is needed to move the 9-1-1 system to a next generation architecture; (2) leadership requires, most notably, more effective state oversight to provide both funding and logistical support; and (3) localities should remain responsible for providing access to 9-1-1, but that they must be supported from higher levels of government as well as industry to exercise that responsibility. On the last point, we must emphasize that it is critical that federal and state governments, in conjunction with 9-1-1 technology leaders, help develop the necessary statement of requirements and standards for a new 9-1-1 technological architecture as well as provide the tools for local or regional PSAPs to utilize advanced technologies.

Following this Introduction, Part I of this Article discusses the

4. Other fractured but related information systems face similar policy challenges. Indeed, emergency communications represents only one area of government services attempting to improve collaboration across jurisdictions in order to better realize technology benefits. See CTR. FOR TECH. IN GOV'T, UNIV. AT ALBANY, SUNY, NEW MODELS OF COLLABORATION: AN OVERVIEW 1 (2004), available at http://www.ctg.albany.edu/publications/reports/new_models_exec/new_models_exec.pdf (analyzing instances where "government reform and new technologies has opened new opportunities to redesign public services").

5. In particular, we interviewed officials from 21 states (Alabama, California, Colorado, Indiana, Louisiana, Massachusetts, Michigan, Minnesota, Montana, New Mexico, North Carolina, Ohio, Oregon, Pennsylvania, South Dakota, Tennessee, Texas, Vermont, Virginia, Washington, and West Virginia), a leading consultant (L. Robert Kimball), service providers (Comcast, Qwest, Skype, T-Mobile, Verizon Wireless, and Vonage), vendors (Cisco, Intrado, Neustar, and Plant CML), associations (E911 Institute, Comcare, CTIA, and NENA), and the federal government (Department of Transportation).

history of 9-1-1. Part II details the traditional architecture of the 9-1-1 system and outlines the opportunities created by a next generation architecture. In laying the two models side-by-side, we do not believe that policymakers have a choice whether or not to migrate to an advanced technology platform. The rationale for doing so is simply overwhelming. Thus, the relevant questions are how soon will such a transition take place and how will it take place? The first question is one of political will and awareness, partially explained by the fact that policymakers have remained in the dark about just how stressed and limited our 9-1-1 system is. The second set of questions focuses on the challenges in terms of governance and funding reforms necessary to upgrade our 9-1-1 capabilities and services.

In terms of the development of a 9-1-1 system, it is critical that state governments appreciate and seek to demonstrate to localities the value of next generation technologies. In so doing, they can provide critical leadership and funding sources to enable the development of a next generation 9-1-1 system (“NG9-1-1”). Specific to state leadership, as we explain in Part III, states need to examine their models of governance to ensure that they provide the support, guidance, and oversight necessary to facilitate the transition to NG9-1-1. On the matter of funding examined in Part IV, we detail the current state of the system and note the often irrational funding strategies to support 9-1-1. Significantly, we do not believe that, on the whole, the amount of money being raised is necessarily insufficient, but rather that the funding procedures and strategies now in place are often not well conceived, fail to adequately promote capital expenditures, and are ineffectively directed to facilitate an expedient transition to a new technological architecture.

In short, there is an important opportunity for thoughtful leadership and vigilant policy reform that will serve the goals of 9-1-1 emergency response far more effectively than the policies currently in place. We believe that the time for action is now.

I. THE HISTORY AND BACKGROUND OF 9-1-1⁶

Today’s telephone subscribers expect to be able to dial 9-1-1 to obtain emergency assistance from their local law enforcement, fire, and emergency medical services (collectively, “First Responders”). As consumers increasingly adopt wireless phones, Voice over Internet Protocol (“VoIP”) services, and other advanced communications technologies, they generally expect that such services will enable them to reach 9-1-1 just as they can from an ordinary landline telephone. This

6. We acknowledge Valerie Yates for her helpful research and assistance in drafting this part.

consumer expectation, however, also underscores a grave source of concern for policymakers and industry professionals: because consumers are often unaware of the limitations of 9-1-1 service in various geographic areas or with respect to certain technologies, they are apt to be disappointed—and left in the lurch—when such technologies fail to reach 9-1-1 or provide the precise location of the caller. The recent tragedy at Virginia Tech, for example, reinforced the weakness of our current 9-1-1 system, as students attempting to text message 9-1-1 were disappointed to find that our 9-1-1 system has yet to embrace this functionality.

With the development of residential telephone service, the telephone became a lifeline for subscribers needing emergency assistance. Before the implementation of the 9-1-1 dialing code, however, it was not always clear which authority to call or which telephone number to use. In 1967, President Johnson's Commission on Law Enforcement and Administration of Justice issued a report (the "Johnson Commission Article") observing that:

When trying to call the police from an ordinary telephone, a person is faced with a bewildering array of police jurisdictions and associated telephone numbers. In the Los Angeles area alone, there are 50 different telephone numbers that reach police departments within Los Angeles County. It should be possible to use a single telephone number to reach the appropriate police department (or some other emergency center) directly.⁷

For reasons of expedience, subscribers commonly dialed "0" to reach the operator and ask for help. The operator would then determine the appropriate authority—generally, a PSAP—and transfer the call. At that time, telephone companies advertised the emergency calling service provided by their operators, which reinforced the importance of access to emergency services. Although this practice made it easy to remember what number to call, the use of operator-assisted dialing wasted valuable time because these calls were not prioritized over the other calls requiring the operator's assistance. Moreover, operators were generally not trained as thoroughly as today's call-takers to handle emergency situations (which were a very small percentage of the incoming calls), thereby introducing a margin for error into dangerous situations and resulting in needless losses of life and property.

To enhance public safety, policymakers embraced the concept of a single, memorable, emergency calling code in the late 1960s. In

7. INST. FOR DEF. ANALYSES, TASK FORCE REPORT: SCIENCE AND TECHNOLOGY (1967), *available at* http://www.911dispatch.com/911/history/task_force_rpt.html.

particular, the Johnson Commission Article recommended that:

Wherever practical a single number should be established, at least within a metropolitan area and preferably over the entire United States, comparable to the telephone company's long-distance information number. This is difficult but feasible with existing telephone switching centers; it appears more practical with the new electronic switching system being installed by the telephone companies, and should be incorporated. In the interim, the telephone companies should print on each telephone number disc the number of the police department serving that telephone's location.⁸

Despite federal support for the initiative, the federal government did not formally authorize or establish a nationwide emergency calling number. Indeed, Congress did not formally establish 9-1-1 as the universal emergency assistance number until 1999.⁹ The informal efforts to spur the establishment of such a number resulted from the leadership of Lee Loevinger, the Defense Commissioner of the Federal Communications Commission ("FCC"), who urged AT&T to develop and implement a universal emergency telephone number.¹⁰ Following this request, AT&T selected 9-1-1 as the emergency calling number and agreed that all Bell System companies would establish circuits that would route 9-1-1 calls directly to a central emergency switchboard to be established, staffed, and controlled by local emergency agencies. As Loevinger put it: "The establishment and operation of a unified emergency agency switchboard center with trained attendants shifts the problem of knowing what facilities are available and of determining which agencies are best able to provide help from the panic-stricken, helpless citizens to the experienced, informed and presumably skilled attendants."¹¹

In a memorandum accompanying a correspondence with the Honorable Joseph A. Califano, Jr., Loevinger outlined some of the obstacles he encountered in seeking to persuade AT&T to implement an emergency calling code.¹² In particular, AT&T objected to the move on the grounds that it would be difficult to reconcile the jurisdictional issues associated with having a single number for disparate and potentially rival organizations; the company would need to incur the costs of

8. *Id.*

9. Peter P. Ten Eyck, Note, *Dial 911 and Report a Congressional Empty Promise: The Wireless Communications and Public Safety Act of 1999*, 54 FED. COMM. L.J. 53, 61 (2001) (analyzing Congressional action via 1999 Act).

10. Letter from Lee Loevinger, *supra* note 1.

11. *Id.*

12. *Id.*

implementing this change; and emerging technological developments would supersede the proposed system, quickly rendering it antiquated.

Despite its now outdated network design, the legacy 9-1-1 system has worked reasonably well. Indeed, because the system is all too often viewed as “good enough,” policymakers have overlooked its antiquated technological premises and vulnerabilities. As we explain in Part II, however, the advent of wireless telephones has underscored these vulnerabilities, leaving many wireless callers without the benefits of location identification information when they call 9-1-1 and preventing such callers from passing along valuable information such as photos when they access 9-1-1.

With respect to governance, localities (and, to a lesser degree, states) have taken the lead in developing 9-1-1 and the subsequently developed “enhanced 9-1-1” (or “E9-1-1”) services for traditional wireline, circuit-switched telephone service. In all cases, the ability to support 9-1-1 service depends on the establishment of available PSAPs, which vary in size and structure from locality to locality. Notably, the geographic territory served by PSAPs range from a single local municipality, to a large city, to a county-wide or regional district, to an entire state. Similarly, the governance structure of PSAPs vary widely as well. Many of them are housed within a branch of public safety or law enforcement, such as the police department, fire department, or sheriff’s office; others are managed by an independent board that oversees a civilian force of trained call-takers. To make matters more complicated, sometimes the PSAP function, i.e., the operator who takes calls from the public, is combined with the dispatch function (which communicates with First Responders in the field) whereas in other instances, the two are entirely separate from one another.

For almost 30 years after the Johnson Commission recommendation to establish a universal emergency number, the FCC did not formally exercise jurisdiction over 9-1-1 related services. With the growth of wireless services (and more recently VoIP services), however, the FCC has asserted its jurisdiction over E9-1-1 insofar as it has formally required wireless carriers to provide access to 9-1-1. In particular, the FCC enacted rules extending the requirement to provide basic and enhanced 9-1-1 service to wireless phones in 1996. As we discuss in Part II, the rules governing wireless carriers called for two phases of compliance: (1) a Phase I where they were required to provide PSAPs with a callback number and location of the cell site/antenna sector receiving the 9-1-1 call; and (2) a Phase II where wireless carriers were required to provide PSAPs the location of all 9-1-1 calls by latitude and longitude.

Just as 9-1-1 technology and governance developed on an *ad hoc*,

jurisdiction-by-jurisdiction, piecemeal basis, as the 9-1-1 system expanded to accommodate more than wireline technologies, so did funding mechanisms for 9-1-1. Indeed, the funding system that emerged after the introduction of newer, post-wireline technologies has resulted in a suboptimal process. Notably, during the 1970s, the initial costs of implementing 9-1-1 were absorbed by the telephone companies and the local communities they served. Starting in the 1980s, however, as part of a strategy to spur the deployment of E9-1-1—which sends calls to the correct PSAP through the action of a Selective Router and an associated database—a fee on telephone bills was implemented to pay for the necessary technological upgrade. In the 1990s, moreover, many states adapted their laws to institute fees for wireless services, often to enable PSAPs to upgrade their technologies so that they could receive information from wireless carriers. Most recently, many states have amended their laws to require subscribers of VoIP services to contribute to the support of E9-1-1 services.

The establishment of fees to support the development of 9-1-1 services underscored the importance of the previously ignored questions of who would manage decisions about ongoing operations, maintenance, and upgrades necessary to support an effective 9-1-1 system. Significantly, the issues around managing the emergency communications network include the fundamental question of what elements should be defined as within that network, i.e., should merely communications technologies be supported, should the costs of buildings used by PSAPs be included, and should the radio dispatch systems used to reach First Responders be included? Moreover, states have taken different positions on whether 9-1-1 surcharges could be used to reimburse telephone companies for the costs of connecting to the PSAPs. Stated simply, the decisions about how to use and manage these funds, like the decisions about what type of funding strategies to use, were often made on an *ad hoc* basis. Once such decisions were made, however, states often left them unchanged despite concerns that the current framework failed to spur technological upgrades.

The lack of any technological upgrade to the 9-1-1 system relative to the broader telecommunications system is particularly pronounced following the advent of Internet Protocol (“IP”)-based voice services and other broadband technologies. For example, early VoIP services often failed to provide access to 9-1-1—despite being marketed in some cases as a replacement service for traditional telephone service—and PSAPs, which generally lacked any broadband capability, could not receive information in an Internet Protocol-based (“IP-based”) format. In June 2005, the FCC addressed one side of the issue (related to how VoIP providers operate) by requiring providers of “interconnected VoIP

services”¹³ to provide access to E9-1-1.¹⁴ As with wireless services, VoIP services can be “nomadic,” i.e., a VoIP subscriber can take her phone with her and use it around the world, making the provision of location information difficult at times. Thus, in addition to requiring VoIP providers to notify their customers of the relevant limitations of the service vis à vis E9-1-1, the FCC has continued to investigate what automatic location capabilities can be implemented for both wireless and interconnected VoIP services.

As to the requirements imposed on wireless and VoIP providers, it is important to appreciate that wireless, VoIP, and other broadband-based technologies are unable to communicate with the 9-1-1 network in an advanced (i.e., digital and IP-based) format and thus cannot do so in an efficient or effective manner. Rather, because the 9-1-1 network continues to use antiquated analog technologies, it is unable to take advantage of “next generation” technologies. To be sure, the 9-1-1 system has thus far survived as a patchwork of old technologies and operates in a reasonably effective albeit limited manner. But it is indisputable that the 9-1-1 network’s lagging technological capabilities both limit what the network can do and render it less effective than modern commercial networks. Part II turns to this very dilemma, explaining how the 9-1-1 system works and how a next generation 9-1-1 system would operate.

II. THE TECHNOLOGY OF THE 9-1-1 NETWORK

A. Introduction

In this part of the Article, we explain the evolution and current state of this country’s 9-1-1 system as well as identify and describe its constraints and shortcomings. We also outline the elements and architecture of a Next Generation 9-1-1 system (“NG9-1-1”) that would overcome these constraints and shortcomings as well as provide a sound platform for its future evolution. As noted above, we do not view the migration to such an architecture as a matter for debate: an NG9-1-1 is plainly superior to the technology currently in place and implementing an enhanced system of emergency communications is critical to protecting

13. “Interconnected VoIP services” are those VoIP services that allow a user to receive calls from and make calls to the traditional “public switched telephone network” or PSTN. In practice, this means that services like Vonage, which use 10 digit phone numbers, must provide E9-1-1 access whereas services like Skype, which uses a username, need not do so.

14. E911 Requirements for IP-Enabled Serv. Providers, *First Report & Order & Notice of Proposed Rulemaking*, 20 FCC Rcd. 10,245 (2005), available at http://hraunfoss.fcc.gov/edocs_public/attachmatch/FCC-05-116A1.pdf.

life and property and ensuring our homeland security.

In Section B, we describe how the original wireline E9-1-1 system evolved from a technical perspective and how the early requirements were met by building upon analog technologies available in the late 1960s and early 1970s. In particular, we explain how the original wireline E9-1-1 system was “jury-rigged” upon what ultimately proved to be a dead-end signaling and transmission system. Moreover, we outline how the changes and modifications to that system have failed to overcome the fundamental constraints and shortcomings associated with the continued reliance upon an increasingly outdated basic technology.

In Section C, we explain how the original wireline system was adapted, and is still being adapted, to facilitate the delivery of 9-1-1 calls from wireless and, more recently, VoIP callers. In so doing, we explain how policymakers called for two distinct phases of access to 9-1-1 for wireless providers—one with the caller’s number and the cell site and another with specific location information as well—without seeking to improve the basic underlying 9-1-1 infrastructure. Similarly, we detail how the effort to enable nomadic VoIP devices to connect to 9-1-1 services did little or nothing to address the constraints and other shortcomings associated with the continued reliance upon the outdated wireline E9-1-1 infrastructure.

In Section D, we discuss these technological constraints and shortcomings in detail, explaining how they have created an E9-1-1 system that literally chokes off the use of all but the most rudimentary features of modern end-user devices and stifles the development of more specialized equipment and services. In particular, we explain how the legacy technology uses a hierarchical structure that creates single points of failure. Moreover, the legacy system’s use of analog signaling as well as its lack of broadband data connectivity among independently operated PSAPs both undermine the ability to improve the system’s performance and frustrate cooperative efforts among PSAPs to improve performance, efficiency, and reliability. Finally, Section D also explains how the continued reliance upon antiquated analog technology means that public safety agencies and the public they serve will not benefit from the improved performance, economies of scale, and declining costs associated with modern digital, IP-based systems.

To conclude our technical discussion, Section E builds upon the work of experts in the field and the weight of recent analyses to set forth the basic architecture for an NG9-1-1 system built upon a modern, secure, digital, packet-switched, IP-based broadband platform. In particular, we explain how such a platform could handle E9-1-1 calls from virtually any end user device (PDA, landline phone, computer) served by any type of call delivery network (wireline, satellite, wireless)

using any available mode (voice, text, data, image and video). We further explain how such a network would enable E9-1-1 calls and critical information associated with the call (such as the caller's location) to be seamlessly transferred between and among PSAPs, thereby facilitating cooperative arrangements among PSAPs that would improve performance in critical situations, increase overall reliability, and promote significant efficiencies. Finally, we explain how such a platform would enable the PSAP community to benefit from the same technological advances and declining costs that telecommunications service providers and their enterprise customers are currently enjoying.

B. Background and Evolution of Our Nation's 9-1-1 System¹⁵

The 9-1-1 system still used in the United States dates back roughly four decades. In the earliest implementations of wireline 9-1-1, the switch in the local telephone company Central Office interpreted or translated the easily dialed and easily remembered sequence "9-1-1" and forwarded or routed the call to a single PSAP (as illustrated in Figure 1). Except for the use of the special number "9-1-1" and some added, specialized functionality, the call was switched or routed in the same as any other call. As limited and outdated as this arrangement is, it is still in use in some parts of the U.S. today.

Figure 1: Basic 9-1-1 Service Architecture

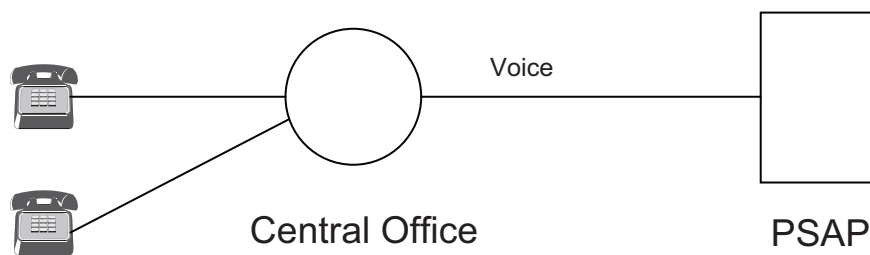

While this arrangement (or "architecture") had the advantage of not

15. The descriptions in this section rely heavily upon the following references: BILLY RAGSDALE ET AL., NAT'L EMERGENCY NUMBER ASS'N, 9-1-1 TUTORIAL (2007), available at <http://www.nena.org/florida/Directory/911Tutorial%20Study%20Guide.pdf>; and DALE N. HATFIELD, A REPORT ON TECHNICAL AND OPERATIONAL ISSUES IMPACTING THE PROVISION OF WIRELESS ENHANCED 911 SERVICES (2002) [hereinafter HATFIELD REPORT], available at http://gulfoss2.fcc.gov/prod/ecfs/retrieve.cgi?native_or_pdf=pdf&cid_document=6513296239 (prepared for the Federal Communications Commission).

requiring any major modifications to the incumbent provider's existing network, it suffered from three significant limitations. First, it provided no automatic means of delivering the telephone number of the calling party (i.e., the call back number) for use in the event the call was disconnected. Second, it did not automatically provide the call taker at the PSAP with the location of the caller seeking emergency assistance. Third, because the geographic area served by a telephone company Central Office might not match the relevant political boundaries, the call might be routed to the "wrong" PSAP (viz., a PSAP which communicates with First Responders whose jurisdiction does not include the caller's location). Moreover, without the relevant location information, a PSAP generally did not have an easy or efficient way to determine who the correct PSAP might be, thereby wasting valuable time in an emergency situation.

Over time, steps were taken to overcome these three limitations and, subsequently, to adapt the 9-1-1 system so that it could handle new forms of call delivery (e.g., wireless and VoIP calls) as the telecommunications market evolved. As we discuss below, however, these refinements and additions were largely built (or, perhaps more accurately, "jury-rigged") upon an analog platform that reflected the legacy telephone technology of the time the system was first designed. Moreover, some industry participants point to the reluctance and, in many cases, the unwillingness of the public safety community to fund longer range solutions rather than rely upon these short-term fixes as a major contributor to the current situation. As a result, the limitations of this now-antiquated analog platform continue to constrain the provision of efficient and advanced emergency services to the public. The promise of overcoming these continuing constraints provides a compelling case for the development and deployment of an NG9-1-1 system.

The first limitation, the lack of a call back number, was overcome by the adoption of Automatic Number Identification ("ANI") technology. As a business practice, the calling number was captured to enable telephone companies to properly bill for long distance toll calls and the automation of that process required the introduction of the ANI technology. This ANI technology was then adapted for use in the 9-1-1 system. Using the ANI technology, the calling number was captured by the switching equipment in the Central Office and relayed to the PSAP along with the emergency call to provide the call taker with the call back number. This arrangement is illustrated in Figure 2.

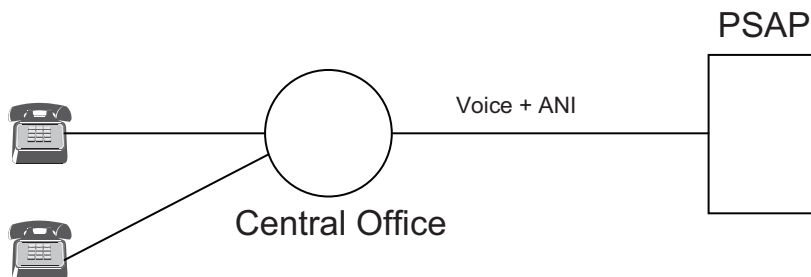
Figure 2: Basic 9-1-1 Service Architecture with ANI

The second limitation, the lack of caller location information in the original wireline implementation, was overcome through the creation and utilization of a specialized database for emergency service use. For billing and other purposes, a Local Exchange Carrier (“LEC”) must be able to associate a particular telephone line and number with a subscriber’s name and address. This information is used to create the specialized 9-1-1 database which is known as the Automatic Location Identification (“ALI”) database. This specialized database makes the necessary association between the telephone number and the name and address information. Conceptually at least, the LEC could deliver this additional information—the name and address (location)—along with the ANI information using the architecture illustrated in Figure 2. As other reports have explained, constraints associated with the legacy analog platform effectively precluded this arrangement and, as a consequence, the PSAP generally uses the ANI information that is delivered to query the ALI database over a separate data circuit.¹⁶ Notably, under this arrangement, the ALI database is usually situated at a central location in the network and serves numerous PSAPs as illustrated in Figure 3.¹⁷

16. HATFIELD REPORT, *supra* note 15, at 4.

17. Because of the critical role played by the ALI databases, they are typically deployed in geographically dispersed pairs to provide needed redundancy in the event of a failure. To simplify the diagram, this redundancy is not shown in the accompanying figure.

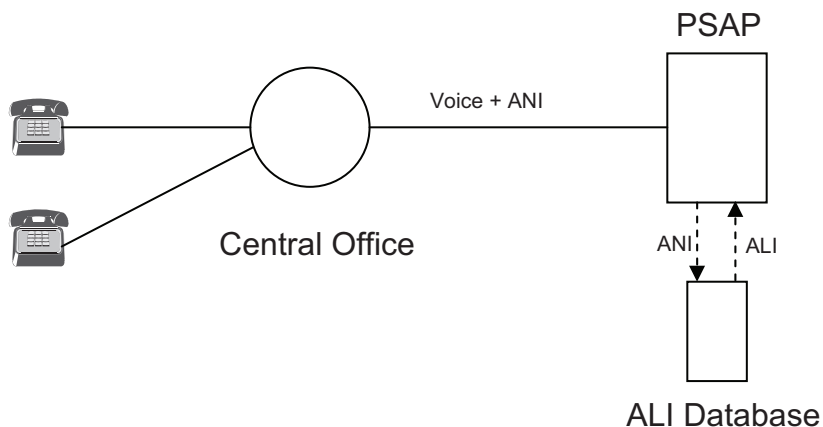
Figure 3: Basic 9-1-1 Service Architecture with ANI and ALI

The third limitation, the challenges associated with delivering the emergency call to the proper PSAP, was overcome through the introduction of an additional, “higher level” Tandem Office switch known as a “Selective Router” and another specialized database known as the “Selective Routing Database” (“SRDB”).¹⁸ In an area containing multiple Central Offices and multiple PSAPs, it is uneconomical to directly connect each Central Office to each of the multiple PSAPs. Instead, the 9-1-1 calls from a number of Central Offices are aggregated at a Tandem Office and delivered over a single connection (i.e., group of “transport trunks”) to the proper PSAP. In the usual case where there are multiple PSAPs, the Tandem Office performs the selective routing function necessary to deliver the call to the proper PSAP. To do so, it accesses the SRDB, which associates each telephone number served by one of the subtending Central Offices with the proper PSAP. Creating this logical association—between the calling number and the proper PSAP—requires the development of another database known as the Master Street and Address Guide (“MSAG”). In particular, the MSAG links the street address associated with the telephone number to a particular PSAP and provides information about the different emergency service agencies that respond to that location.¹⁹

Significantly, it is the Selective Router function that distinguishes

18. In actuality, a new switch was not necessarily required. Instead, additional features and functionality to accomplish the selective router functions can sometimes be added to existing (e.g., Tandem Office) switches.

19. This is necessary because police, fire, and emergency medical jurisdictions may not overlap with each other exactly. For example, a given household at a particular street address may be served by a county-wide law enforcement agency but by a community-based volunteer fire department.

basic wireline 9-1-1 from E9-1-1. In the classic wireline E9-1-1 scenario, the emergency call along with the ANI information is delivered to the Tandem Office containing the Selective Router (the E9-1-1 Control Office) via the Central Office serving the caller. In turn, the Selective Router in the E9-1-1 Control Office determines which PSAP should receive the call by querying the SRDB and then relaying the call and associated ANI information to that PSAP. Using that telephone number as its guide, the equipment located at the PSAP utilizes a separate data link to the ALI database to retrieve the caller's address, the emergency services information corresponding to the calling number, and, in some cases, the name of the subscriber associated with that number. This E9-1-1 architecture or arrangement is illustrated in Figure 4.²⁰

Figure 4: Enhanced 9-1-1 Service Architecture

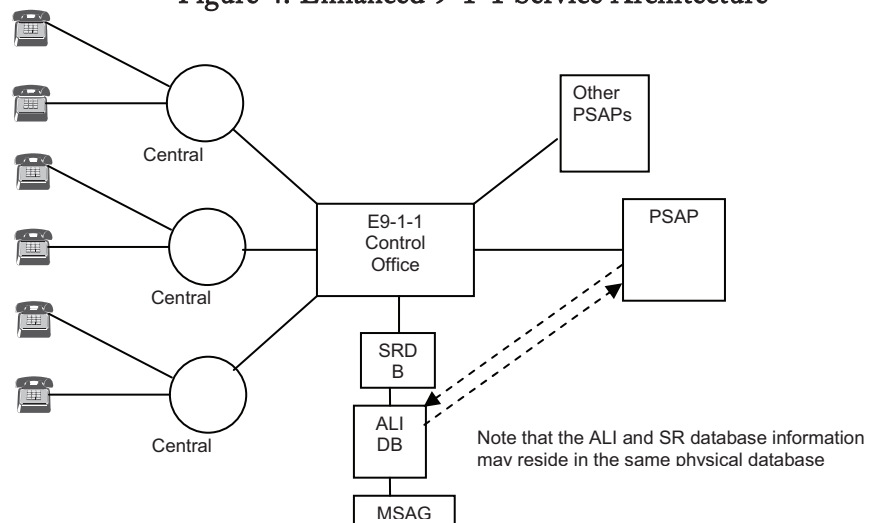

Today's E9-1-1 system in the U.S. is largely built upon the architecture represented in Figure 4. As discussed, it relies upon antiquated analog transmission and circuit-switching technology. To appreciate the outdated nature of the relevant technology, consider that the connections between the E9-1-1 Control Office and the subtended PSAPs use a form of multi-frequency ("MF") signaling²¹ that now is at

20. Because of the critical role played by the ALI and Selective Routing databases, they are typically deployed in geographically dispersed pairs to provide needed redundancy in the event of a failure. Once again, to simplify the diagram, this redundancy is not shown in the accompanying figure.

21. Signaling involves the exchange of control information between the end user customer and the network or between elements (e.g., switching machines) interior to the

least two technological generations out-of-date. MF signaling was originally designed decades ago to handle inter-office call signaling in the public switched telephone network. When deployed in the 9-1-1 system, the use of such existing technology was justifiable on the grounds that it allowed wireline E9-1-1 to be rolled out faster than it might have been otherwise. But that time is long gone and the consequence of continued use of that analog technology is a technologically limited system of emergency communications.

The limits of the legacy technology used in emergency communications can be best understood by viewing the 9-1-1 system as an analog island in a digital sea. Where all of the telecommunications world has transitioned to digital technology, the connections between the E-9-1-1 Control Office housing the Selective Router and the PSAP typically still utilize analog "CAMA transport trunks,"²² which carry signaling information as "in-band" (i.e., audible) MF tones as explained above. This has at least two pernicious consequences: (1) the time it takes to establish or "set up" a 9-1-1 call is far longer than necessary; and (2) the amount of associated information that can be conveyed as the call is setup is severely constrained.

Having outlined the limits of the legacy technology and observed that all telecommunications providers have long abandoned analog systems for digital ones, it is difficult to understand why the 9-1-1 network, which carries such important information, lags beyond the rest of the telecommunications world. The answer, as we discuss in Parts III and IV, has a lot to do with fragmented and sometimes ineffective leadership and the lack of appropriate funding models and related incentives. But there is a technological component as well. Namely, it is important to appreciate that PSAPs long ago purchased or leased Customer Premises Equipment ("CPE") compatible with this now antiquated architecture—meaning that modernizing the existing architecture typically requires the upgrading of PSAP CPE as well as learning to use that new CPE. As a study of Missouri's 9-1-1 system found:

In most cases, PSAP CPE has not kept pace with the rate of change in technology. Many PSAPs continue to use key-set style CPE installed in 1993. This equipment is not computer based and the display screens are small, which limits the information that can be

network. Signaling is used to establish, disconnect and otherwise control the call itself. It is separate and distinct from the actual telephone message or conversation. For a more detailed explanation of signaling, see HATFIELD REPORT, *supra* note 15, at 3-4.

22. CAMA is an acronym standing for Centralized Automatic Message Accounting. CAMA trunks were originally developed to convey signaling information necessary for the telephone companies to automate the billing process for long distance toll calls.

displayed. . . . In several cases, PSAPs are using equipment that is no longer supported by manufacturers or is supported only under special contracts.²³

Indeed, to appreciate the severe limitations of technological architecture and how it has a constraining effect of its own, consider the fact that some jurisdictions have yet to make the transition from basic wireline 9-1-1 to E9-1-1.

C. Adapting the 9-1-1 Network to Allow Wireless and VoIP Calls

By the early 1990s, when policymakers became increasingly concerned about the inability of wireless telephones to reach 9-1-1, the wireline E9-1-1 network was already out-of-date. Nonetheless, rather than chart a new technological course and adopt advanced technology, policy makers often required (at least as a practical matter) wireless devices and, more recently, nomadic VoIP devices to use the legacy 9-1-1 system. In particular, the FCC opened a rulemaking proceeding in 1994 that proposed requiring wireless telephone providers to enable the same level of access to 9-1-1 service as that available to wireline subscribers.²⁴ Notably, unlike their wireline counterparts, it was not self-evident how wireless providers could determine and report the caller's location to the PSAP. Because of the challenges associated with developing the necessary technology to determine and report on a mobile subscriber's location, the FCC divided compliance into two stages known as Phase I and Phase II.

Under Phase I, wireless carriers are required to provide to the PSAPs the callback number and the location of the cell site/antenna sector receiving the 9-1-1 call. Under Phase II, in addition to the callback number, the wireless carriers are required to provide to the PSAPs the estimated latitude and longitude ("X-Y coordinates") of the caller's device. In Phase I implementations, a set of non-dialable telephone numbers known as "pseudo ANIs" or "pANIs" is assigned to each cell site/antenna sector. In a mobile wireless network, the equivalent of a wireline carrier's local Central Office is the Mobile Switching Center ("MSC"). The cell sites or base stations connect to the MSC via microwave or wireline backhaul facilities. When a MSC

23. L. ROBERT KIMBALL & ASSOC., REPORT OF CURRENT PUBLIC SAFETY ANSWERING POINT AND 9-1-1 INFRASTRUCTURE SUBMITTED TO THE STATE OF MISSOURI 25 (2006) [hereinafter L. ROBERT KIMBALL & ASSOC. PSAP REPORT FOR MISSOURI], available at <http://www.911.oa.mo.gov/pdffiles/Report1.pdf>.

24. Revision of the Commission's Rules to Ensure Compatibility With Enhanced 911 Emergency Calling Sys., *Notice of Proposed Rulemaking*, 9 FCC Rcd. 6170 (1994).

receives a 9-1-1 call, a processor associated with the switch knows the cell site/antenna sector where the emergency call is coming from and selects an unused pANI from the set associated with that cell site/antenna sector to facilitate routing. The MSC then forwards the 9-1-1 call along with the pANI to the legacy E9-1-1 Control Office.

Thus wireless access to E9-1-1 was jury-rigged onto the existing network by “tricking” the legacy system into viewing wireless callers as comparable to their wireline counterparts. More specifically, the Selective Routing Data Base is given information so that it can determine what particular PSAP relates to the pANI (and its associated cell site/sector). Based on this determination, the E9-1-1 Control Office or Selective Router forwards the call (along with the associated pANI) to the PSAP’s CPE.

To complete the “tricking” of the legacy network, the MSC also relays a key (i.e., the pANI information) to the ALI database so that the PSAP can gain access to that information. In particular, at the same time that the MSC forwards the call to the E9-1-1 Central Office, the associated processor also provides the call back number of the mobile unit and Phase I location information to the ALI database. Thus, when the PSAP’s CPE receives the call and pANI from the E9-1-1 Control Office, it is able to query the ALI database using the pANI and receive in return the call back number and cell/site sector information, which it can then display for the dispatcher.

At one level, the jury-rigging of the legacy 9-1-1 system was an ingenious solution. After all, the use of pANIs as a database retrieval key enabled the existing wireline E9-1-1 infrastructure to be used for wireless Phase I implementations with minimal modifications because the pANI key was simply substituted for the ANI information and the wireline E9-1-1 portion of the network continued to operate much as it always did.²⁵ While this arrangement had the advantage of allowing wireless Phase I implementations to move forward more quickly and thereby save countless lives in the interim, it did nothing to alleviate the technological constraints and other shortcomings associated with the use of the outdated wireline E9-1-1 infrastructure with, among other things, its reliance upon a dead-end analog CAMA technology. Rather, at least in some cases, it actually created additional reliance interests in that outdated system by requiring new investments in the legacy technology.²⁶

25. It should be noted that, while actual modifications to the wireline portion of the network were minimized using this approach, a substantial amount of additional equipment and effort was needed in order to effectively interface the wireless carriers’ equipment, information, and processes with the legacy wireline E9-1-1 network.

26. See, e.g., Letter from Thomas J. Sugrue, FCC Chief, Wireless Telecomms. Bureau, to Marlys R. Davis, E-911 Program Manager, King County E-911 Program Office (May 7,

The Phase II vision of wireless compliance with E9-1-1 could not be implemented as quickly as Phase I. In particular, Phase II required the wireless carrier to deliver the callback number and the geographic location or “X-Y” coordinates of the caller to the PSAP. In principle, this information could be relayed in a similar fashion to that approach described above, except additional equipment would be needed to determine the position of the caller. This equipment, known as Position Determination Equipment (“PDE”), estimates the location of the wireless subscriber placing the 9-1-1 call both at the start of the call and, if needed, during the progress of the call.

Once the position is estimated, the MSC receiving the emergency call is able to forward it and the Phase I pANI to the E9-1-1 Control Office or Selective Router just as it does in the case of a Phase I call. As before, the E9-1-1 Control Office uses the Phase I information stored in the Selective Routing Data Base (i.e., the information that associates the pANI and its related cell site/sector with a particular PSAP) to deliver the call and pANI to the proper PSAP.²⁷ When the PDE locates the mobile terminal, it also provides the pANI, call back number and location information, i.e., X-Y coordinates, to the ALI database over another data link.

On the PSAP side of the equation, the Phase II process works slightly differently from Phase I. Notably, when the PSAP’s CPE receives the call and pANI from the E9-1-1 Control Office or Selective Router, it queries the ALI database using the pANI. The ALI database returns the call back number and Phase II location information, which is then processed and made available to the call-taker, assuming that the PSAP has upgraded its CPE so that it can receive and utilize this information. Note that during the call, the location information can be refreshed over the data link between the PDE and the ALI database. The E9-1-1 network architecture with the wireless elements added is illustrated in Figure 5.

2001), *available at* <http://www.fcc.gov/Bureaus/Wireless/Orders/2001/kingco.pdf> (explaining demarcation of the point up to which wireless carriers are obligated to bear costs for Phase I implementation—“the proper demarcation point for allocating costs between the wireless carriers and the PSAPs is the input to the 911 Selective Router maintained by the Incumbent Local Exchange Carrier (ILEC)”).

27. The call could be routed based upon the Phase II (X-Y) information, but, typically, this is not done due to the delay that occurs between the time the wireless 9-1-1 call is placed and the estimated X-Y coordinates are available from the PDE and associated Mobile Positioning Center (“MPC”).

Figure 5: Enhanced 9-1-1 Service Architecture Supporting Wireless

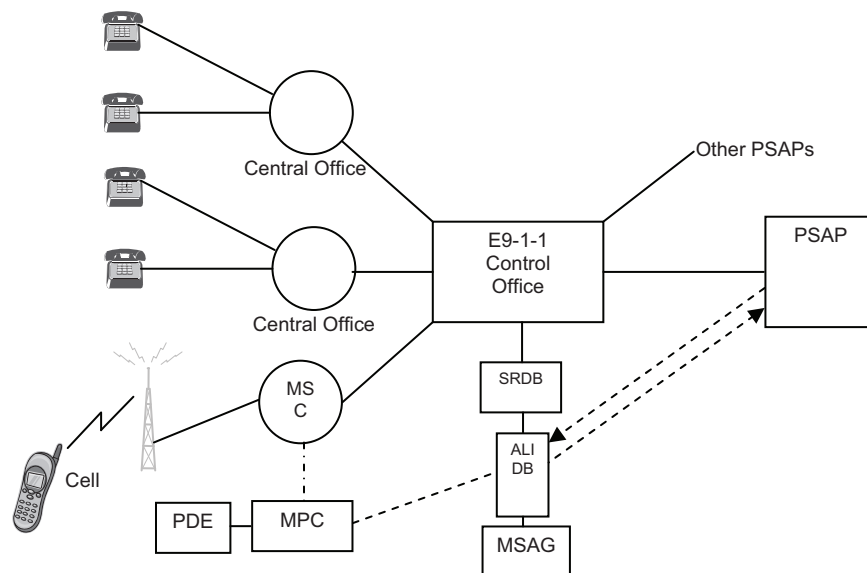

As suggested above, the FCC responded to the advent of VoIP technology by requiring VoIP providers who offered services that interconnected to the public switched telephone network to also offer E9-1-1 service to their subscribers. For entities such as cable television companies that offer VoIP to fixed devices (i.e., “fixed-line VoIP”), the solution was relatively straightforward as they possessed the necessary location (street address) information of the caller and, assuming access to the Selective Routers and associated E9-1-1 databases was available, they could readily interface with the existing wireline E9-1-1 network. As in the case of wireless E9-1-1, the major challenge in providing nomadic VoIP services is to determine the location of the subscriber and his or her device.

In the VoIP environment, the providers of nomadic VoIP services lacked a practical means of locating nomadic devices, such as a Vonage phone that can be taken abroad and plugged into an Ethernet port to receive “dialtone” and act like an ordinary phone with a number associated with the North American Numbering Plan. To address this failing and to comply with FCC requirements, providers like Vonage have required their subscribers to manually enter their current address over the Internet. The provider then provides this subscriber location

information to the appropriate E9-1-1 databases. With this arrangement, an emergency VoIP E9-1-1 call is passed, along with the ANI information, through a “gateway”²⁸ to the E9-1-1 Control Office and, ultimately, to the correct PSAP. The CPE at the PSAP then utilizes the data link to the ALI database to retrieve and display the call-back number, subscriber name (in some cases), address, and emergency services information associated with the calling number.²⁹ To illustrate the current architecture of the E9-1-1 network architecture, Figure 6 outlines how it integrates the wireline, wireless, and VoIP elements.

Figure 6: Enhanced 9-1-1 Service Architecture Supporting Wireless and VoIP

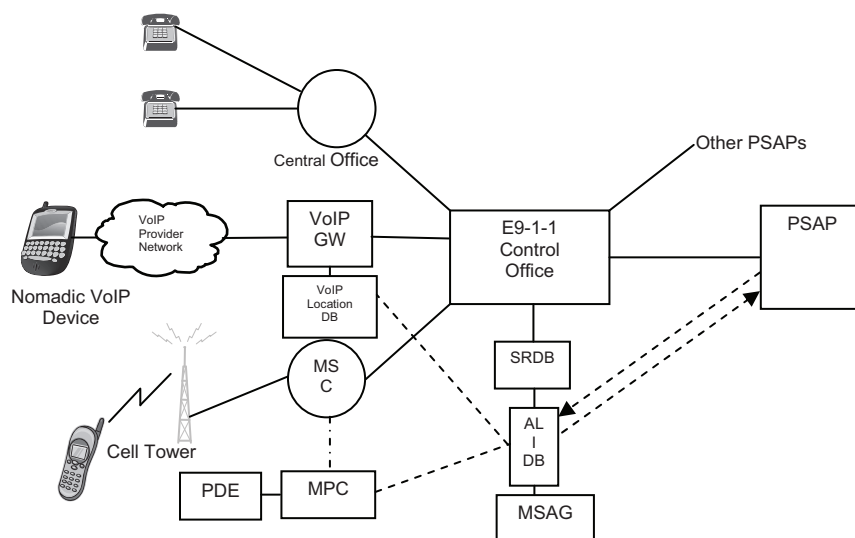

28. In this context a gateway is simply a device that converts VoIP calls on one side of the device to ordinary public switched telephone network (“PSTN”) calls on the other.

29. VoIP providers are migrating to E9-1-1 compliance in three stages referred to as I1, I2, and I3. In the first stage, I1, the 9-1-1 call is routed to the ordinary ten digit telephone number of the PSAP (sometimes referred to as an administrative line) without location information. In the second stage, the VoIP provider participates in the updating of the ALI database and the 9-1-1 call is routed along with the ANI information over the incoming trunks to the correct PSAP. The PSAP can then retrieve the caller’s location information by querying the ALI database as usual. The third stage refers to the future situation wherein the PSAP is able to receive 9-1-1 calls and associated information directly in the IP-format without conversion.

D. Constraints and Shortcomings Associated with the Current 9-1-1 System

In the previous section, we traced the evolution of the Nation's system for handling 9-1-1 emergency calls and emphasized how that system relies upon the badly outdated wireline E9-1-1 infrastructure. As one of us concluded in an earlier report released in 2002, "[T]he wireline E911 system . . . was jury-rigged upon a dead-end CAMA technology that continues to constrain the evolution of wireless E9-1-1 service."³⁰ As the same report put it, "While the Nation should be forever grateful to the engineers and others who designed the original 911 system, it must be recognized that it was—and remains—somewhat of a 'kluge.'"³¹

In this section, we discuss the constraints and shortcomings associated with the current generation of E9-1-1 systems. It is important to appreciate those limitations and constraints not only because they create the urgent need for the development and deployment of NG9-1-1 systems in general, but also because they are crucial to understanding the requirements for how such systems must be governed and funded in the future. With that in mind, we now turn to a discussion of the constraints and shortcomings associated with the current E9-1-1 system.

1. Constraints on Serving and/or Exploiting Modern End-User Devices

When the first 9-1-1 call was completed in 1968, telephone subscribers by and large accessed the telephone network using ordinary telephone handsets designed to do nothing more than: (a) convert voice sounds to variations in electric current on the outbound side of the line, (b) convert variations in electric current to voice sounds on the incoming side, and (c) handle the simplest of signaling functions, e.g., dialing and ringing. By contrast, modern state-of-art handsets, especially those used on wireless networks—let alone VoIP networks—are entirely different.

Today's wireless devices are, in many cases, an electronic swiss army knife. In particular, these small digital devices have powerful processor and storage capabilities and are capable of creating and handling not only voice communications, but also text, data, image, and video signals and combinations of them (multimedia) as well. Unlike the voice-oriented, analog, circuit switched technology that lies at the heart of the existing E9-1-1 system in the U.S., today's wireless networks increasingly—like

30. HATFIELD REPORT, *supra* note 15, at 10.

31. *Id.* at 14.

the broadband networks utilized by VoIP providers—use modern, all-digital packet switched technology based upon the Internet Protocol suite.³² Consequently, these networks are capable of conveying voice, text, data, image, and even video signals from these increasingly powerful digital devices.³³

If our nation relied on a 9-1-1 network based on cutting-edge broadband Internet Protocol-based technology (and not based on antiquated analog technology and MF [CAMA] signaling), it could take advantage of, rather than cripple, the capabilities of modern end-user devices. Consider, for example, that most modern cell phones could easily send along pictures to a PSAP (say, of a car leaving the scene of an armed robbery), but few PSAPs are equipped with the necessary technology to be able to receive and process such information. Similarly, the adoption of enhanced IP-based technology would enable a deaf person who relies upon the text messaging features of a modern wireless phone to communicate electronically with a PSAP by sending a text message to the 9-1-1 call-taker. The message could request help and convey relevant information about the emergency situation.³⁴

The adoption of modern, broadband IP-based technology would not only allow our 9-1-1 system to take advantage of current capabilities, but also to develop specialized devices and functionalities tailored to particular emergency response scenarios. With the aid of such technology, for example, firms could develop and market technologies that would not only allow an elderly person living alone to use a simple pendant-type device to call for help, but also to automatically convey other critical (e.g., medical) information as well. Similarly, an Automatic Collision Notification system in a vehicle could automatically call for help while conveying other relevant information such as the vehicle's

32. Protocols are simply pre-established rules implemented in software or hardware that facilitate electronic communications between and among computers and other devices. A protocol suite is thus a set of such protocols. In particular, the Internet Protocol suite is the set of protocols upon which the Internet runs. Note, as we will explain later, that private data networks that are entirely separate from the public Internet can be implemented using the Internet Protocol suite.

33. In fairness, it should be pointed out that while wireline public switched telephone networks have largely been converted from analog to digital switching and interoffice transmission, most residential subscribers still access the digital network over narrowband, analog local loop or "last mile" facilities. Thus, PSAPs are not unique in relying upon analog facilities in an increasingly digital era. However, a technology known as Digital Subscriber Line ("DSL") gives many of those residential subscribers the option of accessing the public Internet over broadband facilities that support voice, data, image, and video signals in the digital format as well as traditional narrowband analog voice signals. In the alternative, some ILECs are extending broadband digital capacity to individual homes using fiber optic rather than twisted-pair copper cable facilities.

34. Jim McKay, *Texting 911?*, GOV'T TECH., Aug. 1, 2007, available at <http://www.govtech.com/gt/127961>.

location and the severity of the crash. Finally, the adoption of modern technology would enable operators of commercial, third-party operated (telematics) emergency services (e.g., Onstar, ATX and CrossCountry), burglar alarm companies, and remote health monitoring centers all to more efficiently and effectively convey emergency information to the appropriate First Responders.³⁵

In evaluating the opportunity to upgrade the capacities of 9-1-1 services, it is important to recognize that if only the network connection were upgraded, that alone would not be sufficient to facilitate the use of enhanced technologies such as those discussed above. In particular, even with the adoption of a modern all-digital, broadband, IP-based packet switched network (i.e., one capable of conveying voice, text, data, image, and video traffic) for 9-1-1 traffic, PSAPs would still lack the capability to receive, process, and display such information without upgrading their CPE. As noted above, the CPE in today's PSAPs are generally configured to receive emergency calls over analog CAMA trunks (with all of the attendant constraints) and to request and receive information associated with the call over rather rudimentary, low-speed, point-to-point communications links connected to the ALI database. Paraphrasing one of the E9-1-1 professionals we interviewed during the project, "upgrading the network side of the system without upgrading the PSAP equipment itself will only move the bottleneck or chokepoint from the last few miles to the last few feet."³⁶ Moreover, as we discuss in the next part related to governance, it is also crucial that the right training and incentives are put in place so that PSAPs not only adopt advanced technology, including CPE, but also learn how to use it effectively.

Another important consideration to appreciate in evaluating the opportunities presented by advanced technology is to recognize the inevitable resistance to technological change. This Article discusses strategies to overcome such resistance in the next part, but it bears mention that many of the criticisms of the enhanced, IP-based technologies are not well founded. First, some maintain that IP-based networks are unsecure or unreliable. But, as we will explain in more detail later in conjunction with our discussion of the NG9-1-1 network,

35. These third party providers are often forced to access PSAPs over administrative lines rather than the regular E9-1-1 trunks. In some cases, these administrative lines may not be staffed with trained emergency call takers and, in extreme cases, may not be staffed on a 24/7 basis. It should be noted, however, that requiring this mode of operation is not always a purely technological problem since operational issues such as excessive false alarms may require manual screening of calls by third party providers.

36. In order to elicit candid responses in interviews, we agreed to provide anonymity where credible sources volunteered potentially sensitive information. Accordingly, where this Article cites an interview without personally identifying the speaker, it is pursuant to such an agreement.

one can use IP-based equipment on a private, managed, and secure network that is physically separate from the public Internet. This separate network can ride, for example, on a fiber optic cable configured as a self-healing ring that provides an additional level of reliability over and above the diverse routing capabilities of IP-based networks. This separation from the public Internet coupled with modern encryption techniques could provide the requisite level of security and reliability. Indeed, many mission critical networks rely upon similar arrangements today.

A second criticism leveled by some E9-1-1 professionals against the modernization of the E9-1-1 platform is that the ability to receive more information delivered by end-user devices will overload the call-taker in the PSAP with information. To be sure, this is a legitimate and plausible concern. It fails to appreciate, however, that whether and when a call-taker receives information is a matter of software design and that all information need not be presented to the call-taker when the call is received or in progress. If a PSAP was served by modern all-digital, broadband, IP-based packet switched network, the additional information (e.g., the photograph of the fleeing suspect or the information on the severity of the crash) could be conveyed but, rather than displaying this information to the call-taker and/or dispatcher, it could simply be stored in a database attached to the network for later retrieval.³⁷

2. Constraints Associated with Analog Circuit Switching and Selective Routers

Stated simply, the 9-1-1 network remains a voice-centric environment in a data-centric world. Notably, the connections between the Central Office that handles the emergency call and the E9-1-1 Control Office—as well as between the E9-1-1 Control Office and the PSAP—are optimized for voice communications and hence severely limit the bandwidth available for data communications. Similarly, the Selective Routers in the E9-1-1 Control Office constrict the bandwidth available because they are also optimized to handle voice traffic.³⁸ To be sure, the use of Selective Routers ensures that calls are delivered to the correct PSAP and distinguishes other forms of 9-1-1 service from E9-1-1. Nonetheless, it does so at a great and now unnecessary cost to innovation in the 9-1-1 network.

37. In this scenario, the information can then be retrieved or “pulled” when, and only when, it is wanted by the call taker, dispatcher, or first responder.

38. Note that this bandwidth constriction is true whether the trunks are using an analog or digital format.

The technological limitations imposed by the use of traditional circuit-switched Selective Routers present problems other than constraining bandwidth available to applications beyond the core voice delivery function of today's network.³⁹ By requiring a hierarchical structure for E9-1-1 calls to be delivered, the use of Selective Routers creates a potential single point of failure. Consider, for example, that if the Selective Router fails, emergency calls via Central Offices connected to that Selective Router will not be delivered. One remedy for this concern is to deploy two Selective Routers at two different locations with separate independent trunks from each subtending Central Office to each of the redundant Selective Routers and from each of the two Selective Routers to each PSAP. As should be evident, however, this approach comes at a considerable cost and often cannot be borne by the relevant PSAPs, with the result that the 9-1-1 network is often vulnerable to at least one single point failure.

In reality, the traditional circuit-switched Selective Router as a point of failure is matched by the specter that the PSAP itself represents another single point of potential failure insofar as PSAPs typically have no back-up arrangements—at least outside of those PSAPs connected to the same Selective Router—should they suffer an outage based either on their network or CPE infrastructure.⁴⁰ Notably, the existing 9-1-1 network is limited in terms of allowing one PSAP to backup another in the event of failure or in a period of unusually high call volumes. Thus, in a state or region with a large number of Selective Routers, the requirement to be served by the same Selective Router limits the ability of more distant PSAPs to provide backup support. Moreover, as a historical matter, the presence of different telephone carriers in different areas as well as the existence of incumbent rate centers and LATA boundaries have created seams that make such cooperation difficult.⁴¹ In

39. Clearly, the function provided by the traditional Selective Routers in today's 9-1-1 network (i.e., routing the call to the appropriate PSAP based upon the caller's location) is still needed in the NG9-1-1 network; by contrast, in a broadband, packet-switched, IP-based network, the bandwidth constraints would be removed and numerous other benefits, as explained herein, would result.

40. We are not aware of any publicly available, comprehensive study of E9-1-1 system failures. Based upon conversations with professionals in the field, however, we believe that individual PSAPs remain the single weakest link in the E9-1-1 chain and it is our understanding that individual PSAP outages are not reported in most cases. These outages are caused by PSAP physical plant and/or public utility failures, CPE failures within the PSAP, or failure of the telephone company outside plant (i.e., the local loop and transport facilities) that are used to connect the PSAP to the E9-1-1 network. The latter type of failure isolates the PSAP from the balance of the network and the risk of such isolation can be reduced by deploying redundant, diverse physical routes into and out of the building housing the PSAP.

41. LATA refers to "Local Access and Transport Area," which was the term adopted by the court overseeing the AT&T consent decree. The LATA boundaries thus defined the areas within which the Bell Operating Companies could deliver phone calls and where calls

short, technological constraints and politically defined boundaries make it difficult to create a more cohesive state-wide or regional E9-1-1 network even if different agencies were inclined to cooperate with one another on a broader scale.

To make matters worse, even where cooperation is technically feasible and politically viable, the existing technology limits the effectiveness of such cooperation. In particular, current constraints based on the use of old signaling technology and the lack of broadband communication links between PSAPs limits the ability of call-takers to transfer data that has already been collected from the caller along with the call when it is transferred from one PSAP to another. By contrast, users of modern call centers managed by businesses such as airlines generally take for granted that information taken by one operator can be passed along to another. In a cruel irony, it is the 9-1-1 network where such capabilities are at a premium—and not for those airline customers, for example—as the loss of precious seconds while the call-taker in the other jurisdiction collects the same information a second time can be a matter of life and death. Moreover, this limitation has other spillover effects as it discourages cooperation that might give rise to a range of efficiencies, such as shared foreign-language-speaking call-takers, call-takers during slow periods, and specialized databases or software programs.

3. Constraints Associated with In-band Multi-frequency CAMA Signaling

For many casual users and observers of telecommunications technology, the importance of signaling technology often goes unappreciated. Such technology, while largely hidden from view, plays a key role in handling all telephone calls—including emergency calls to 9-1-1—and is sometimes referred to as the “nervous system” of telecommunications networks. As described above, the in-band, analog MF signaling that is used to deliver the ANI information between the E9-1-1 Control Office and the PSAP is a particularly primitive and outdated form of signaling. Consequently, it is slow and has limited capacity compared to modern forms of signaling.

The limitations of MF signaling undermine the effectiveness of the 9-1-1 network in two important ways. First, its slow speed prolongs call setup time (which can exceed 5 to 10 seconds), thereby wasting seconds that are precious when responding to emergencies. Indeed, in extreme cases where the call setup delay is long enough, this delay may have the

could only be handled by the so-called “long distance companies” like AT&T and MCI (who carried “inter-LATA” calls).

pernicious effect of leading the caller to think that the call has not gone through rather than still being processed. In such a situation, the caller may simply abandon the call only to try again and receive the same delay. This not only results in the waste of precious seconds, but also unnecessarily adds to the traffic load on a system that may already be under stress in a disaster situation. Second, because MF signaling information is transmitted in an analog format, i.e., as audio tones, it is also more prone to errors than its more reliable digital signaling counterpart.

A third limitation that results from the use of MF signaling is that critical information associated with a call cannot be carried along with the call itself. As explained above, wireless networks are capable of discerning the X-Y coordinates (and potentially Z, the altitude information that may indicate the floor of a high-rise building) of a caller when they achieve Phase II compliance. Given the constraints of MF signaling, however, such information cannot be carried along with and delivered simultaneously with the call. Rather, in the current architecture, the PSAP must request the additional information over a separate datalink. This additional step may result in increased delay in the delivery of information associated with the call. This delay may not be consequential if the call-taker does not need the information immediately, but the limitations of MF signaling constrain the ability of the designer to choose between what information is delivered simultaneously with the call and what information is delivered later based upon a database query.

The limitations of MF signaling are easily remedied through an upgrade to the more modern and widely adopted form of signaling known as "Signaling System No. 7" ("SS7"). Unfortunately, this will not occur so long as the E9-1-1 network continues to rely upon CAMA signaling between the E9-1-1 Control Office and the PSAP. As a result, the E9-1-1 network will be constrained by the performance of those trunks and the associated equipment at the PSAP. In an insult on top of injury, not only is the performance of the E9-1-1 network constrained by the use MF signaling—the weakest link in the signaling chain—but the use of that technology requires an extra device or gateway to translate between more modern forms of signaling (e.g., SS7) and the MF signaling which can cause additional call setup delay. Finally, because the CAMA equipment used to support MF signaling is no longer specified or used in the ordinary Public Switched Telephone Network ("PSTN"), it is more difficult to maintain and there is little or no incentive for manufacturers to improve its performance.

4. Constraints Associated with Fixed Point-to-Point Data Links

As explained earlier, today's E9-1-1 architecture includes a point-to-point, non-switched data link between the equipment at the PSAP and the ALI database. It is not unusual to find this data link operating at extremely low speeds and over analog facilities using antiquated modems rather than over modern high-speed, digital facilities. These low-speed links can slow the time between when a query is initiated and the ALI information is delivered to the call-taker. Moreover, the limited MF signaling capacity described immediately above, coupled with the limited connectivity and capacity of these low-speed dedicated point-to-point data links, severely constrains the ability of call-takers/dispatchers in a PSAP serving one area to efficiently share information with call-takers/dispatchers in a PSAP serving another area. As we noted in our discussion of traditional circuit-switched Selective Routers, the lack of broadband communications links between and among PSAPs limits the ability of call-takers to automatically transfer data that has already been collected from the caller along with the call when it is transferred from one PSAP to another. More generally, the lack of switched, broadband data communications links between and among PSAPs and other public safety and governmental agencies not only means that precious seconds may be lost while call-takers exchange information verbally or collect it a second time from the caller, it also reduces important performance measures such as call processing time and reliability. Finally, because the current architecture creates "isolated PSAP islands," it discourages efficiencies that could be gained by sharing expensive or specialized personnel and information resources between different PSAPs.

E. Elements and Architecture of the Next Generation 9-1-1 System

Having described the current E9-1-1 architecture and the constraints and shortcomings associated with that architecture, we now move to describe a Next Generation 9-1-1 ("NG9-1-1") system that would diminish—and, in some instances, alleviate—these constraints and limitations. In particular, we outline how an NG9-1-1 system should follow the path of commercial enterprises by using a modern, secure, and reliable digital, packet-switched, IP-based broadband platform capable of receiving and processing emergency calls in increasingly diverse and powerful ways. As we explain, such an NG9-1-1 system would enable emergency 9-1-1 "calls" from a myriad of different devices to connect to the system over a wide range of competitive access networks.

1. Introduction to Next Generation Technology and Its Application to 9-1-1

First, it is useful to conceive of the entire E9-1-1 network as consisting of three parts: (1) call delivery, (2) call processing, and (3) radio dispatch. These three parts are depicted in Figure 7.

Figure 7: Elements of a NG9-1-1 System

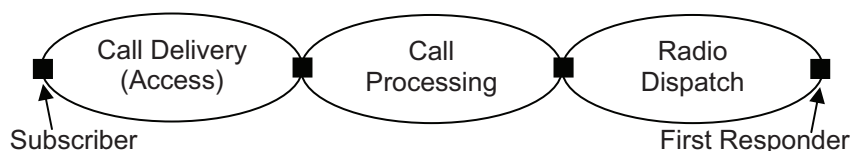

Call delivery consists of picking up the emergency call at the subscriber's terminal device and delivering the call and associated information, including the location of the device, to an interface at the Selective Router (or its equivalent). Call delivery is accomplished over an access network so named because it is the portion of the broader network used by subscribers to obtain access to voice, text, data, image, video services, or combinations thereof. In an earlier era, the only network that delivered calls was that operated by Incumbent Local Exchange Carriers ("ILECs"). Today, however, an array of providers deliver such calls, including Competitive Local Exchange Carriers ("CLECs"), wireless providers, and Voice over IP ("VoIP") providers.⁴² Indeed, more 9-1-1 calls are delivered today by non-ILEC subscriber access networks than by the ILECs themselves.⁴³

Call processing consists of picking up the call and location information at the input interface of the Selective Router or its equivalent, delivering the call to the correct PSAP, determining the nature of the emergency and the needed response, and handing the call off to the dispatcher. Call processing thus includes the Selective Router or its equivalent, the switching and transmission facilities for delivering the call to a call-taker, plus the supporting CPE, computers, databases,

42. Note that today, the PSAP must take a specific action—a database dip into the ALI database—to obtain the location of the caller. In the future, we assume that all access providers will be responsible for delivering the location information with the call.

43. See, e.g., N.H. OFFICE OF LEGISLATIVE BUDGET ASSISTANT, STATE OF NEW HAMPSHIRE ENHANCED 911 SYSTEM: PERFORMANCE AUDIT REPORT 2 (2006) [hereinafter N.H. PERFORMANCE AUDIT REPORT], available at http://www.gencourt.state.nh.us/lba/PDF/E911_2006.pdf ("According to a 2003 [Bureau of Emergency Communications] report, an estimated 33,000 of 64,000 calls (52 percent) received during a two-month period were placed from wireless phones.")

and other information processing equipment utilized by a PSAP. In some cases, where the call-taker and dispatcher functions are combined, the interface between the call processing function and the dispatch function will be in the mind of that person. By contrast, where the functions are split, the call processing function includes the delivery of the necessary information on the call to the proper dispatcher of the needed First Responders, e.g., law enforcement, fire, or emergency medical personnel.

Radio dispatch consists of receiving the information about the emergency call and dispatching one or more First Responders and associated assets to the scene, taking into account a host of factors such as the location and nature of the emergency, and the location and status of First Responders and other assets in the field.

In the remainder of this section, we focus our attention on the second part of the overall network described, i.e., on the call processing portion illustrated in Figure 7. Before so doing, however, we offer three preliminary observations. First, it is important to appreciate that the radio dispatch portion of the overall network also suffers from a number of important constraints or limitations. Foremost among these limitations are: (1) bandwidth constraints that limit the ability of the dispatch function to support the delivery of broadband services (e.g., high-speed data, image and video) to and among First Responders and (2) limitations on interoperability which severely limit badly needed coordination among different first responder groups especially when different jurisdictions or levels of government are involved (as in a mutual aid situation).⁴⁴ These issues are beyond the scope of this Article, but it is important to highlight for our purposes that a modern, secure, and reliable digital, packet-switched, IP-based broadband platform that supports the call processing or PSAP portion of the overall network could also provide the fixed (e.g., fiber optic based) part of the next generation, interoperable, broadband wireless dispatch network that is now being developed.

Second, it is important to recognize the implications of an environment where the call processing portion of the overall network is supported by a modern, secure, and reliable digital, packet-switched, IP-based broadband platform. As we will discuss in more detail below, such a platform removes the signaling and data communications constraints that now prevent the rapid seamless sharing of information among PSAPs and other public safety and governmental agencies. By so doing,

44. DALE N. HATFIELD & PHILIP J. WEISER, SILICON FLATIRONS TELECOMMS. PROGRAM, TOWARD A NEXT GENERATION NETWORK FOR PUBLIC SAFETY COMMUNICATIONS 11-13 (2007), *available at* <http://www.silicon-flatirons.org/documents/publications/policy/HatfieldWeiserPublicSafetyCommunications.pdf>.

it saves precious seconds in call processing time, increases reliability by facilitating backup and load-sharing arrangements,⁴⁵ and encourages efficiencies that could be gained by sharing expensive or specialized personnel and information resources.

Third, before proceeding to explain the architecture of an IP-based NG9-1-1 system, it merits explanation that the use of Internet technology does not necessarily involve the use of the public Internet *per se*. Consider, for example, that the Internet Protocol suite or family of protocols is widely used by corporate America to enable “Intranet” systems that connect branch offices, key suppliers, and valued customers. Such a network is maintained as a secure and managed network that, while utilizing the same protocols as the public Internet, is entirely separate from it.

From a technical perspective, the concept of a “next generation” architecture is taking on a standardized meaning across different environments ranging from classic wireline telephony, to cable television, to wireless telephony, and to emerging networks such as WiMAX systems. Next generation networks replace analog, narrowband technology with digital, broadband technology and use packet-switching facilities that support all kinds of applications—voice, text, data, image, video, and multimedia combinations thereof—on a multipurpose network. Moreover, next generation networks almost universally use the IP suite of standards and protocols as a means of logically organizing their respective platforms and as a way of routing packets of information—voice, text, data, image or video as the case may be—between different platforms and over diverse types of transmission media, e.g., fiber optic cable, coaxial cable, twisted pair copper cable, or radio spectrum.⁴⁶

In the case of a next generation network for 9-1-1, there are three powerful reasons why the Internet Protocol suite of protocols should support the NG9-1-1 platform. First, since the different access networks providing the call delivery portion of the overall network are or will be using IP packets and the IP protocol suite to interconnect with other

45. Load sharing would be helpful in exigent circumstances where call takers are busy. For example, a recent TV news station’s investigation of Valley Emergency Communications Center—which serves six Salt Lake, Utah-area cities and Salt Lake county—found that “the center’s internal memos and [KSL’s] investigation reveal it doesn’t matter if it’s a busy time or not. Calls made at 3 a.m., 11 a.m., and 8 p.m. were all put on hold with people waiting minutes for a live person.” Debbie Dujanovic, *911 Nightmare Uncovered in Investigative Report*, KSL.COM, Nov. 1, 2007, <http://www.ksl.com/index.php?nid=481&csid=2077061>.

46. An IP packet of information is sometimes analogized to standardized shipping containers that can be used to convey a wide variety of content such as television sets, clothing, household goods, and machinery on a wide variety of transportation vehicles such as containerized ships, railroad cars, or truck trailers. The standardized container facilitates interconnection among the different transportation modes.

networks, it makes sense for the NG9-1-1 system do the same to be compatible. In particular, this eliminates or reduces the amount of processing that is necessary at the interface between the call delivery and NG9-1-1 call processing portions of the overall network. Second, since traditional narrowband, circuit switched technology is being rapidly abandoned, vendors and the academic research community are focusing their attention and financial resources on IP-based broadband digital networks. Unless the NG9-1-1 system relies upon this same fundamental technology, it will not be able to benefit from the improved performance, economies of scale, and declining costs that are associated with this seismic shift in industry direction. Third, the decentralized control associated with certain aspects of the IP-based architecture provides for an ability to route packets around network failures, thereby promoting greater end-to-end reliability of the network. This open (rather than proprietary) architecture provides great value to end users because it diminishes the chances of “vendor lock-in.”

2. The Case for a Next Generation Architecture for E9-1-1

To develop our notional description of an NG9-1-1 system, we have relied heavily upon the work of experts in the field, including the forward-looking work of certain vendors. Most notably, however, we draw upon the description in the a recent publication entitled “Next Generation 9-1-1 System Initiative: Concept of Operations” published by the Intelligent Transportation Division of the U.S. Department of Transportation (“DoT”).⁴⁷ In particular, the DoT vision calls for a next generation 9-1-1 initiative that would: (1) “[e]nable E9-1-1 calls from any networked communications device,” (2) “[e]nable geographic-independent call access, transfer, and backup among PSAPs and between PSAPs and other authorized emergency organizations,” (3) “[e]ncourage a flexible, open, non-proprietary, and secure architecture to facilitate the implementation of an interoperable internetwork” of all emergency organizations, and (4) “[m]aximize emergency services capital, operations, and maintenance cost savings.”⁴⁸

47. U.S. DEP’T OF TRANSP., NEXT GENERATION 9-1-1 (NG9-1-1) SYSTEM INITIATIVE: CONCEPT OF OPERATIONS (2007), *available at* http://www.its.dot.gov/ng911/pdf/NG911ConOps_April07.pdf.

48. *Id.* at 8. In principle, an NG9-1-1 system can reduce capital, operations, and maintenance costs over what they would otherwise be to support today’s E9-1-1 functionality. In practice, however, the future costs may actually exceed today’s 9-1-1 costs because of the need to run both the traditional system and the NG9-1-1 system during a transition phase and because of the greatly increased functionality that is enabled by broadband, IP-based technology. Consider, for example, that while the NG9-1-1 network may provide economies of scale and/or scope in transporting voice, text, data, image, and video traffic, additional software and hardware may well be needed at the PSAP to utilize new applications that take

As explained earlier, an NG9-1-1 system can be divided into the three components—call delivery, call processing, and radio dispatch, which are depicted in the high-level diagram set forth in Figure 8 (below). Note that the oval shapes on the left of the Figure 8 represent different types of call delivery or access networks ranging from wireline telephony companies to wireless cellular/PCS companies to VoIP providers to email or Instant Messaging systems. Notably, as for each category, there may be multiple companies and some companies may provide more than one service. Moreover, the rectangular dot at the left of each access network represents the subscriber or end user device whereas the rectangular dot at the right of the oval represents the interface point between the call delivery network portion of the system and the call processing network portion of the system, i.e., the equivalent function of the Selective Router in today's E9-1-1 network.

The large vertically oriented oval represents a state-wide or region-wide, modern, broadband, packet-switched, managed, IP-based network of the type we described earlier. That network both routes the emergency call and associated information (e.g., call back number or its equivalent) to the proper PSAP and provides broadband connectivity between and among the PSAPs shown as smaller ovals toward the right of the figure. Moreover, it provides connectivity to associated shared resources such as specialized databases (e.g., on the characteristics of hazardous materials or the status of emergency medical facilities such as hospitals in the area/region). As for the small rectangular dots between the state-wide or region-wide network and the PSAPs, they represent the interfaces between those networks. Finally, to the right in the figure are ovals representing the radio dispatch networks for dispatching law enforcement, fire, and emergency medical personnel in response to the emergency call.

advantage of the additional capabilities. Moreover, the technological life of the elements comprising the NG9-1-1 system may well be shorter than the equipment that is being replaced with the result that the new elements may need to be upgraded or replaced more frequently.

Figure 8: NG9-1-1 System (Notional)

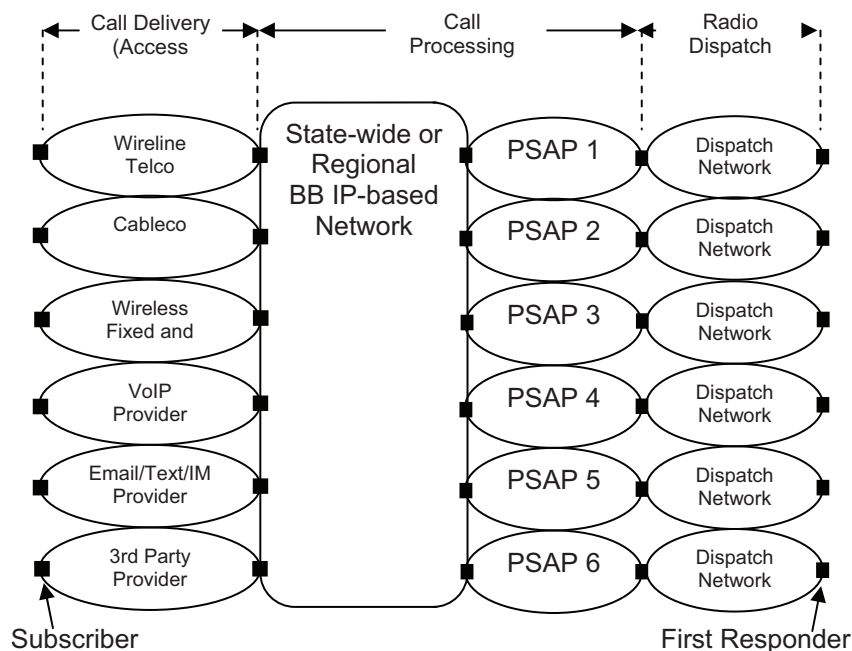

As explained above, this Article focuses on the call processing portion of the system—including the state-wide or region-wide broadband network and the individual PSAPs within the state or region. Significantly, there are two types of advances facilitated by the adoption of an NG9-1-1 system: (1) the ability to provide a more effective service and (2) the ability to do so more efficiently. We will enumerate the points behind each category in turn.

In terms of providing greater levels of effectiveness, there are five principal reasons that an NG9-1-1 network would constitute a dramatic improvement over the traditional 9-1-1 network. First, an NG9-1-1 network would enable E9-1-1 calls to be received from virtually any end user device served by any type of IP-based call delivery (access) network using any available mode—voice, text, data, image, and video.⁴⁹ Second, this network would enable E9-1-1 calls and critical information associated with the call to be seamlessly transferred from one PSAP to any other PSAP connected to the state-wide or regional network.⁵⁰

49. Until the conversion of the existing PSTN to an IP-based network is complete, gateways between the existing E9-1-1 network and the NG9-1-1 call processing network would be required.

50. While transferring E9-1-1 calls and associated information from one PSAP to

Third, an NG9-1-1 network would reduce call setup times, facilitate faster overall response times, and improve the quality of service as perceived by the end users of E9-1-1. Fourth, the use of flexible, open, and non-proprietary standards would facilitate information exchange between and among different emergency responder groups operating at different levels of government by and with appropriate private sector entities—thus facilitating interoperability between them. Fifth and finally, by reducing the threat of “vendor lock-in” and enabling PSAPs to benefit from technological advances transforming the telecommunications sector more broadly, PSAPs would be able to adopt innovations and benefit from declining costs that telecommunications providers and their enterprise customers are currently enjoying.⁵¹

In terms of efficiency, there are three principal efficiency gains that would arise from the implementation of an NG9-1-1 system. First, as noted above and discussed more in the next part, an NG9-1-1 system would facilitate other cooperative arrangements between and among PSAPs connected to the state-wide or regional network, ranging from backup agreements (e.g., to handle call overflows during unexpectedly heavy usage periods or in the event of a major failure at one or more PSAP locations) to agreements to share scarce resources such as call-takers with a particular expertise (e.g., a speaker of a language in addition to English) and agreements to share specialized databases. Second, the adoption of an NG9-1-1 system would enable the automatic delivery of additional information regarding the caller (e.g., voluntarily entered information on the caller’s medical condition) or the caller’s location (e.g., information regarding onsite hazardous materials) that could be retrieved at the option of the call-taker. Finally, an NG9-1-1 architecture would enable the E9-1-1 network to be managed in a

another in the event of a failure or overload conditions is important in the sense that it provides greater assurance that emergency calls will be answered, it is not an end in itself. Rather, the PSAP that ultimately receives the emergency call must be in a position to assist in the appropriate response. If the call is in regard to an incident that has already been reported or if it is simply someone making an inquiry regarding an incident, providing an appropriate response in the form of information may be straight-forward. More extensive coordination among different PSAPs and First Responders is necessary if the call requires the dispatch of personnel and other resources. The NG9-1-1 is a necessary but not sufficient condition for facilitating such cooperation.

51. As one observer stated in a related context:

[T]he public safety user community is two orders of magnitude smaller than the commercial user base. As a result, R&D investments in commercial wireless technologies dwarf those made in public safety wireless technologies. In addition, the large size of the commercial market wireless market fosters greater levels of competition between vendors of network infrastructure, user devices, and applications.

Krishna Balachandran et al., *Mobile Responder Communications Networks for Public Safety*, IEEE COMM. MAG., Jan. 2006, at 56.

modular fashion, with clearer demarcations between responsibilities for call delivery, call processing, and radio dispatch, thereby providing more opportunities for competitive supply of the different elements of the system.

III. TOWARD NEW GOVERNANCE MODELS FOR E9-1-1

The management of calls to 9-1-1 incontestably represents a matter of grave local concern because local—and not federal or state—officials are likely to be the first ones to respond in a case of emergency. It is thus understandable that localities often resist suggestions that statewide oversight is appropriate. As discussed in Part II, however, the technological changes related to the Internet and broadband networks, along with the antiquated state of most 9-1-1-related infrastructure, creates an opportunity for local PSAPs to transition to a more advanced technology platform. Stated differently, PSAPs can begin to share with one another virtually and benefit from economies of scale and scope by becoming users of NG9-1-1 technology. To make this transition, however, localities and operators of PSAPs will need to be willing to cooperate with one another, states will need to ensure reliable sources of funding (see Part IV), and all relevant stakeholders will need to ensure that the appropriate coordination takes place and the necessary technology infrastructure is put in place.

At the outset, we need to emphasize two basic points. First, while we do not recommend a “one size fits all” model—remote rural areas will need to adopt different strategies than dense urban ones—we do believe that some basic governance structures and strategies can help to manage and expedite the transition to an NG9-1-1 system. Second, we recognize that different states have different governmental traditions, such as a stronger commitment to home rule, and that these traditions must be taken into account in devising appropriate governance strategies. In any event, rather than attempt to devise a comprehensive solution, we emphasize strategies that we believe can work across the several states and provide effective governance strategies that go hand-in-hand with the funding strategy recommendations we make in Part IV.

In general, this Part discusses the relevant governance issues, highlighting important reforms that state governments can make to spur progress toward an NG9-1-1 system. In particular, Section A begins by providing some basic background information and Section B outlines the range of governance models used by the several states. Section C then sets forth our conclusions on best practices, suggesting four lessons for state oversight of 9-1-1 networks. Finally, Section D explains the appropriate role for the federal government in this area.

A. Background

PSAPs have emerged as part of local and, in some cases, state governments' provision of fire, law enforcement, and emergency medical services. This development, however, has not reflected any clear or consistent logic or thoughtful strategy. In some states, for example, PSAPs track geographic boundaries such as counties whereas other states, such as Missouri, have some PSAPs at the county level, some at the local level (with 23 PSAPs in one county), and yet others at the regional level.⁵²

As part of the effort to institutionalize "9-1-1" as a universal emergency number, some state governments entered into 9-1-1 matters by establishing state oversight bodies. Such inroads, however, were often viewed with suspicion by local agencies, particularly when they were already operating effectively. Thus, in many states, the real impetus for state involvement came around the push for enhanced functionality for wireless telephones supported by the wireless providers themselves, as they did not want to deal with multiple jurisdictions. Unlike their wireline predecessors, wireless telephones did not necessarily fall within the jurisdiction of a particular PSAP. For example, a commuter with a wireless phone may cross the jurisdictional boundaries of several PSAPs en route to the workplace. Consequently, the effort to oversee the upgrade of their capability and of the PSAPs' ability to process information relayed from wireless phones lent itself more naturally to state oversight spanning multiple PSAP jurisdictions.

As explained in Part II, the emergence of next generation technologies related to the Internet provides new opportunities for emergency communications. Such opportunities, which depend upon a successful migration strategy away from the legacy infrastructure, generally entail the use of new network architectures that can be best provided at the state or regional level. The transition to a next generation architecture, however, is not only a matter of upgrading the relevant equipment. Rather, states must also develop effective governance models to spur the adoption of technological change and to overcome resistance to change.

As we discuss below, the traditional stance that the technology used in wireline E9-1-1 is a matter of local control needs to yield to the exercise of some authority and oversight by state agencies in order to spur the necessary technological development and cooperation that will make possible the use of an advanced communications infrastructure.⁵³ Some

52. L. ROBERT KIMBALL & ASSOC. PSAP REPORT FOR MISSOURI, *supra* note 23, at 4.

53. To be sure, state public utility commissions ("PUCs"), insofar as they regulate

of those we interviewed suggested that local officials appreciated this fact and welcome state oversight. By contrast, others suggested that localities would be reluctant to give up control of traditional prerogatives, including the right to purchase whatever equipment they chose, and thus would resist adopting new technologies. As noted at the outset, however, we do not believe that the opportunities afforded by an NG9-1-1 system are merely discretionary choices that should be left to local control. Rather, the capabilities afforded by such a system are critical to public safety and homeland security and should thus be implemented as soon as practicable.

B. The Range of Governance Models

Unlike many areas of public policy concern, the models of regulation to spur the adoption of 9-1-1 technology on the part of both governments and telecommunications providers vary widely across the several states. Indeed, the extent of the variability is so considerable that the differences cannot be neatly categorized along one dimension. For exposition purposes, we will distinguish between states by the level of statewide leadership they provide concerning the provision of E9-1-1 services. That classification, however, is a crude one, as some states have instituted centralized bodies to address issues related to calls to PSAPs from wireless phones, but not from wireline ones. Similarly, some states have instituted statewide leadership initiatives in theory, but have failed to empower them in practice.

As noted above, many states have entirely separate governance systems to support wireless E9-1-1 than wireline E9-1-1. In Alabama, for example, the State has an E9-1-1 Coordinator, who lacks statutory or formal authority concerning wireline E9-1-1 matters, but has a wireless E9-1-1 Board that is charged with distributing funds to localities. Similarly, in Indiana, there is a state wireless E9-1-1 Board with formal authority, but no such counterpart on the wireline side, which ultimately limits the opportunities for upgrading the entirety of the 9-1-1 infrastructure.

Putting aside the gradations in authority, we conclude that the empowerment of a state 9-1-1 entity makes a material difference in facilitating faster adoption of advanced 9-1-1 technology. Compare, for example, Indiana and Ohio. In Indiana, the state established a well-funded and empowered state wireless 9-1-1 Board with a professional

incumbent providers, do regulate the technology used in 9-1-1 services. Outside of the antiquated model of requiring the incumbent provider to cross-subsidize the provision of 9-1-1 services, however, the PUCs have generally played a limited role in technology adoption decisions.

executive director. Consequently, it has not only implemented Phase II wireless access throughout the state, it has also developed an advanced infrastructure and emerged as a leader in migrating toward an NG9-1-1 system. Notably, Indiana has enabled non-traditional entities like telematics services and SMS messages (on a trial basis) to gain access to the 9-1-1 network. Meanwhile, in Ohio, there is no statewide oversight and the state relies on an advisory board structure that leaves each PSAP free to act autonomously. Notably, even though Ohio collects some 9-1-1 funding at the state level, it automatically disperses it to the local agencies and provides no accountability for how it is spent. Not surprisingly, Ohio has yet to complete the transition to Phase II wireless and, except for some local efforts (like Hamilton County) has not progressed toward an NG9-1-1 system.

The interviews we conducted with all segments of the 9-1-1 world underscored that support for PSAPs in terms of education, funding, and accountability make a considerable difference and that those states with oversight bodies are able to provide those functions far more effectively than those without oversight. These discussions echoed the findings of important studies of the state of 9-1-1, including the Hatfield Report commissioned by the FCC.⁵⁴ Despite the strong consensus on this point, some states—about 15 according to NENA⁵⁵—have not developed any central 9-1-1 coordination function and have fallen behind those states with coordinators in terms of their level of progress on Phase I and Phase II wireless. Notably, even some states with coordination functions, like Colorado, have failed to truly empower their coordinators. Underscoring the weaknesses of the Colorado model, Susan Sherwood from Verizon noted that Colorado has lagged behind other states when it comes to upgrading the 9-1-1 network, noting more generally that “states without oversight bodies are not good at PSAP education” in terms of advancing technologies.⁵⁶

Empowering leaders to spur technological change is an important part of upgrading the 9-1-1 system for a new era. In New Mexico, for example, the state took seriously the need to upgrade its 9-1-1 system and conducted a national search for a highly qualified E9-1-1 Program Director and hired an industry professional (Bill Range) to work in the

54. See generally HATFIELD REPORT, *supra* note 15; see also U.S. GOV'T ACCOUNTABILITY OFFICE, STATES' COLLECTION AND USE OF FUNDS FOR WIRELESS ENHANCED 911 SERVICES 16 (2006) [hereinafter GAO STATES' COLLECTION REPORT], available at <http://www.gao.gov/new.items/d06338.pdf>.

55. For a discussion of central coordination functions, see MONITOR GROUP, ANALYSIS OF THE E9-1-1 CHALLENGE 58, 77-78 (2003) [hereinafter MONITOR GROUP REPORT 1], available at <http://www.911monitor.com/Analysis.pdf>.

56. Telephone interview with Susan Sherwood, E911 Manager, Verizon Wireless (Aug. 8, 2007).

state Department of Finance and Administration. The state also empowered the Office of the Program Director to collect and disperse funding, oversee equipment procurement, and provide support to local PSAPs. As such, New Mexico has already commissioned a feasibility study and aspires to be one of the first states to develop an NG9-1-1 system for both wireless and wireline access networks. By contrast, states that constitute oversight bodies with representatives only from local telephone companies or from any one particular industry segment are less likely to be effective than those with a more representative body and professional administration.

C. Recommended Governance Reforms within State 9-1-1 Management

Policymakers have experimented with different approaches to 9-1-1 over the last thirty years and additional experimentation has occurred over the last ten or so years with respect to wireless E9-1-1. Collectively, these experiences yield some useful lessons. In this Article, we will focus on four such lessons. In particular, we address the importance of: (1) a formally authorized and statutorily codified oversight body, (2) statewide oversight over mission critical networks, (3) an incentive strategy to spur PSAP technological upgrades, and (4) an empowerment strategy toward “PSAP cooperation.”

1. The Importance of an Empowered Oversight Body

In California, the state relied on an informal advisory board for years before the State Legislature codified its commitment to a more formal structure. As Daphne Rhoe, the California 9-1-1 Program Manager and member of the State 9-1-1 Board explained, the statutory codification of the Board was important because it ensured that the Board would have diverse representation.⁵⁷ Moreover, she explained, the added formality raised the profile of the Board because its members were appointed by the Governor, and the Board was required to comply with the Public Meetings Act, ensuring that meetings were accessible to the public.⁵⁸

In Tennessee, the creation of a statewide board composed of, among others, those professionals who run PSAPs and elected officials and the hiring of a professional Executive Director provided critical focus to that state’s efforts to improve its 9-1-1 system. With this model of

57. Telephone interview with Daphne Rhoe, California 9-1-1 Emergency Commc’ns Office Chief, State of Cal. Dep’t of Gen. Servs. – Telecomms. Div., in Sacramento, Cal. (June 28, 2007).

58. *Id.*

governance and the ability to collect as well as disperse funds, Tennessee emerged as the third state to provide state-wide Phase II wireless service. Similarly, in Vermont, where the Legislature passed a 1993 statute calling for an oversight board with broad experience and a professional director, the state rolled out the first state Internet Protocol-based system to support 9-1-1 communications, enabling the state to provide a “virtual PSAP service” available to all public safety agencies in the state. By contrast, other states have failed to ensure that state 9-1-1 Boards were composed with officials with true expertise, thereby sacrificing their ability to provide effective leadership on matters ranging from spurring Phase II wireless services to planning for next generation technologies.

Our findings based on those we interviewed are echoed by other analyses. The National Emergency Number Association (“NENA”), for example, highlighted the significance of an empowered state oversight body in an important 2003 study conducted by the Monitor Group.⁵⁹ Moreover, recognizing that the establishment of such a body along with an implementation plan for upgrading E9-1-1 were commendable practices, Congress required both as a condition of receiving funding under the ENHANCE 9-1-1 Act, which we discuss below.⁶⁰

In advocating for an empowered oversight body, it is important to note that such a body need not exist at the state level. Rather, for larger and more populous states like Texas, such bodies can be created at the regional or district level. In Texas, however, this approach has left the relevant state entity, which oversees and works with more rural areas, less able to support those 9-1-1 agencies not supported by a district. Our interviews reported that districts in Texas were able to all achieve Phase II wireless compliance effectively, whereas the rural areas outside of the districts have yet to do so—highlighting that a lack of statewide oversight can allow some areas to thrive at the same time that others continue to use antiquated technology.

2. Statewide Oversight over Mission Critical Networks

Historically, 9-1-1 networks were provided as part of a “regulatory compact” between the telephone company (mostly the pre-divestiture Bell System) and the public. Unfortunately, the commitment to invest in mission critical networks and spur innovation in such networks was and still is rarely a top priority for the telephone company. Thus, as noted in Part II, much of the current 9-1-1 infrastructure relies on out-of-date

59. *Id.*; see also MONITOR GROUP, ACCELERATING DEPLOYMENT OF NATIONWIDE E9-1-1: SUMMARY FINDINGS OF THE NENA SWAT E9-1-1 STAKEHOLDERS’ INITIATIVE (2003), available at <http://www.911monitor.com/Summary.pdf>.

60. See 47 U.S.C. § 942(b)(3) (2006).

equipment that is difficult to replace and lacks advanced functionality. To remedy this failing, we recommend that a state oversight body should spur the development of an advanced system and continue to oversee its use.

The mandate for state bodies to oversee the operation of a 9-1-1 system would represent a marked departure from the status quo. In many states today, such as California, the relevant state body lacks control to oversee and address network failures. This means that where a crucial 9-1-1 connection goes down, or a service level agreement is not adhered to, the state body cannot sanction the provider. To be sure, it is possible that oversight over such networks can be managed by the Public Utilities Commission (“PUC”). In such cases, however, it is still important that the state 9-1-1 coordinator be involved in that process.

As discussed in Part II, the reliability and functionality of the 9-1-1 system is not only a matter of the state of the network but also the equipment (i.e., the “CPE”) used by the PSAPs. After all, as a thoughtful report found in a study of Missouri’s PSAPs, “[m]ost PSAPs use equipment that cannot be upgraded to accommodate modern public safety communications needs.”⁶¹ To address this concern and ensure that PSAPs adopt and use reliable equipment, many states have also called for the 9-1-1 Coordinator to oversee and approve purchasing decisions.

In practice, a statewide oversight regime focused on equipment usage can operate most effectively when the coordinator or oversight body possesses some control over funding. As one state official put it, “he who has the money makes the rules.” Some state program offices, however, lack either control over funding or approval authority over equipment, preventing them from either assuring the effectiveness of the relevant equipment or facilitating bulk purchasing opportunities. The benefits of statewide oversight are not merely in bulk purchasing; the use of uniform standards in a state facilitates better training opportunities, increased support for the technology, and a higher level of interoperability. In many states, however, use of disparate technologies is the rule. In Missouri, for example, one study found “at least 15 different ALI formats being used.”⁶² In short, state oversight should ensure adherence to a standardized architecture that facilitates greater levels of functionality (i.e., the ability to take advantage of ongoing innovations), as well as enables PSAPs to procure equipment and software at lower costs (i.e., because of the ability to benefit from economies of scale and competition).

61. L. ROBERT KIMBALL & ASSOC. PSAP REPORT FOR MISSOURI, *supra* note 23, at 5.

62. *Id.* at 19.

Finally, the effectiveness of the 9-1-1 network also relies on well-trained operators and users of critical equipment. To ensure that local PSAPs receive appropriate training and operators are qualified to use—and are comfortable with—advanced equipment, state oversight bodies should maintain some form of a certification and re-certification program. In Pennsylvania, for example, the State 9-1-1 Coordinator requires the re-certification of dispatchers every three years. In short, we believe that such practices are important and that states should develop operational standards, provide training support so that they can be easily met, and build in some form of oversight to ensure that they are being met.

3. An Incentive Strategy for PSAP Technology Upgrades

Even in states with a centralized body to oversee aspects of the 9-1-1 system, the respective bodies face considerable challenges with certain PSAPs that, for one reason or another, have failed to invest in technological upgrades. In the case of enabling Phase II wireless capabilities, a number of states have overcome those challenges, but even a number of these states, like Indiana, acknowledge that some PSAPs have maintained antiquated analog equipment. Notably, such equipment either requires the use of converters to translate digital communications to analog or prevents the use of advanced technologies, such as those necessary to enable 9-1-1 access by non-traditional entities like telematics providers and SMS messages. To address the continuing failure of certain PSAPs to upgrade their equipment, we recommend that both education campaigns at the state level and dedicated sources of state funding be provided to fund at least a portion of the necessary upgrade. To be sure, like any sound fiscal strategy, such funding must be coupled with effective oversight to ensure that the funds are spent appropriately.

The starting point for encouraging PSAPs to upgrade their infrastructure is for state bodies to educate PSAPs about new technological opportunities. As Susan Sherwood of Verizon put it, “a lack of understanding leads to hostility.”⁶³ As detailed in the Hatfield Report, some PSAPs remained in the dark about what equipment and software upgrades were necessary to be able to receive wireless E9-1-1 information.⁶⁴ We acknowledge, however, that education alone may not be sufficient to spur PSAPs to embrace technological progress. After all, changing the hearts and minds of PSAPs about the opportunities created by new technologies may not be easy when, at a minimum, significant job re-training will be required and, in some cases, old jobs will no longer

63. Telephone interview with Susan Sherwood, *supra* note 56.

64. HATFIELD REPORT, *supra* note 15, at 30.

be necessary.⁶⁵

To appreciate the cultural changes associated with migrating to a new technological environment, consider the reactions of a few seasoned government professionals. To underscore the gravity of the challenge to overcome the legacy mindset and the attachment to the old ways of doing things, Indiana's Ken Lowden explained that:

Existing deficiencies (inter-agency [data] transfer, for example) have existed for so long that they become the "given" environment. A new network, even though it would address these long-standing deficiencies, is not accepted by [many] PSAPs because 3-4 "generations" of PSAP staff have made the best of a technologically antiquated network. In their minds, 9-1-1 modernization is considered "high risk," and change is to be avoided at all costs to avoid any risk.⁶⁶

Similarly, in the related context of public safety communications, one report observed that:

[T]he history of fiefdoms within the respective agencies obscures the "gains from cooperation." In many cases, managers of legacy radio systems tell chiefs that "you need to stick with the traditional land mobile radio system" or the system won't remain secure. To be sure, education and demonstration projects are part of the answer because there is a basic lack of understanding about how modern networks are designed and managed—for example, security stems from effective encryption, not physically separate networks. Yet education alone will not do the trick. As Chief Werner recounted from his experience, getting beyond the silo-based approach is starting to happen where incentives for cooperation—in the form of federal grants—create opportunities to bring together groups of distinct agencies and individuals through consensus-building leadership.⁶⁷

65. Explaining a similar dynamic in a different context, one observer suggested that: More than that, however, it's clear the changes required won't be a consensus cakewalk. Jobs will change. Careers will change. Status and relationships will change. Some people will see themselves as worse off, perhaps dangerously worse off, even completely without a role in the new order. In such situations, people are rightfully anxious. As e-government moves to the future, reform becomes a game of musical chairs. When the music stops, people must find new chairs, and some won't be able to do so.

Jerry Mechling, *A Sobering Challenge*, GOV'T TECH., Sept. 2, 2005, available at http://www.govtech.com/gt/print_article.php?id=96524.

66. Telephone interview of Ken Lowden, Executive Dir., Ind. Enhanced Wireless 911 Bd., in Indianapolis, Ind. (Aug. 2, 2007).

67. Philip J. Weiser, The Aspen Institute, *Clearing the Air: Convergence and the Safety Enterprise* 24-25 (2006), available at <http://www.aspeninstitute.org/atf/ct/%7BDEB6F227->

Similarly, as Garry Briese put it, “[t]he hardest part of improving emergency warning and recovery efforts is changing human behavior.”⁶⁸

It is important that the use of the financial incentives and demonstration projects by state bodies be coupled with an effective and transparent oversight mechanism. Such mechanisms can vary from audits to reporting requirements designed to ensure that local PSAPs develop and implement viable strategies to adopt advanced technology. Moreover, such mechanisms should ensure that public funds given to local agencies are spent appropriately and that they are using appropriate policies, training, and procurement decisions to implement advanced technologies.

At present, some states, such as Michigan, are already using oversight mechanisms like requiring jurisdictions operating a PSAP to file a 9-1-1 plan with the state. In the case of Michigan, this requirement not only mandates reporting on technological progress, but also on the status of cooperative efforts to ensure that data exchanges shared between jurisdictions are managed in an effective fashion. Articulating requirements are not only a valuable means of enabling oversight (as to matters including cooperation and technology adoption), but they also enable localities to compare their approaches with one another and pressure them not to fall behind their counterparts. In particular, the use of systematic benchmarking as to the relative progress of different PSAPs is likely to be a powerful motivator and means of holding those lagging behind accountable. After all, when areas that fail to adopt technical upgrades leave affected citizens in the dark about what they are missing, that failure may well go unremedied; as Justice Brandeis famously put it, “sunlight is the best disinfectant.”⁶⁹

A core challenge of state oversight and guidance efforts is to overcome the resistance to technological change. Traditionally, local PSAPs have not thought of themselves as smart users of dynamic technology and thus the migration from the legacy model to a next generation one will require a change in the prevailing cultural mindset. To facilitate such a change, the relevant state agency needs to demonstrate the virtues of an NG9-1-1 system, provide important logistical support, and evangelize about the benefits of the new technology. Moreover, state agencies also need to provide financial

659B-4EC8-8F84-8DF23CA704F5%7D/C&S%20FINALAIRSREP06.PDF (quoting Charlottesville Fire Chief Charles Werner).

68. SPACE & ADVANCED COMM’NS RESEARCH INST., GEORGE WASHINGTON UNIV., WHITE PAPER ON EMERGENCY COMMUNICATIONS 2 (2006), available at http://satjournal.tcom.ohiou.edu/issue10/PDF/Final_Version_White_Paper.pdf.

69. LOUIS D. BRANDEIS, OTHER PEOPLE’S MONEY AND HOW THE BANKERS USE IT 92 (Melvin I. Urofsky ed., Bedford/St. Martin’s 1995) (1913).

incentives for local PSAPs to migrate to an NG9-1-1 system. Such incentives must be managed carefully, however, as some past grant programs geared to spur adoption of new technology and change traditional approaches have been criticized as ineffectual.⁷⁰

4. An Empowerment Strategy toward PSAP Cooperation

In almost all states we investigated, the concept of “PSAP Consolidation” is viewed as a dirty phrase. In general, the resistance to mandatory consolidation reflects concerns not only about the possible loss of jobs, but even more fundamentally about the loss of control. For local law enforcement and fire departments, for example, the ability to manage their own call-taking operations is considered a vital component in their emergency response operation. By contrast, the thought of outsourcing that function can thus be seen as challenging their ability to perform their public mission effectively. At the same time, however, there is considerable evidence that localities are willing to enter into voluntary agreements to collaborate and share resources.⁷¹

As discussed in Part II, the use of a modern IP-based NG9-1-1 system can present PSAPs with new opportunities premised on sharing economies of scale and scope. To appreciate this point, consider three real-world weaknesses that many PSAPs routinely face today. First, consider PSAP reliability. With a modern IP-based NG9-1-1 architecture, PSAPs can easily route calls to back-up providers or re-route them if they were sent to them in error. Today, however, most PSAPs employ very crude forms of call transfer that make re-routing difficult and may even not allow for redundant connections. Second, for a PSAP that does not have an operator on duty at all times, a next

70. On the issue of federal grants to spur public safety interoperability, for example, the United States Government Accountability Office concluded that, despite over \$2 billion awarded in grants from 2003 to 2005, “strategic planning has generally not been used to guide investments and provide assistance to improve communications interoperability on a broader level.” U.S. GOV’T ACCOUNTABILITY OFFICE, FIRST RESPONDERS: MUCH WORK REMAINS TO IMPROVE COMMUNICATIONS INTEROPERABILITY 3 (2007), *available at* <http://www.gao.gov/new.items/d07301.pdf>. As to its finding with regard to specific states, it is found that in Kentucky where the “grant reviewers at the state level who are in charge of disbursing DHS grant money to localities have had limited means for determining whether funding requests for equipment and training were compatible with statewide interoperability goals.” *Id.* at 21.

71. A recent New Jersey study concluded, for example, that “about half of the state’s municipalities had entered into regional relationships to carry out 9-1-1 services.” JOHN J. HELDRICH CENTER FOR WORKFORCE DEVELOPMENT, N.J. OFFICE OF EMERGENCY TELECOMMS. SERVS., NEW JERSEY 9-1-1 CONSOLIDATION STUDY: PROFILE OF THE NEW JERSEY E9-1-1 SYSTEM 1 (2005) [hereinafter PROFILE OF THE NEW JERSEY E9-1-1 SYSTEM], *available at* http://www.heldrich.rutgers.edu/uploadedFiles/Publications/New%20Jersey%20State%20Profile%20E9_1_1.pdf.

generation architecture promises the opportunity to maintain service at all times. And third, consider the PSAP that relies on a single operator who does not speak Spanish. Today, that operator is sometimes left without any resources in the event a Spanish speaker calls for help. In an NG9-1-1 environment, by contrast, that PSAP could easily conference in another PSAP operator with Spanish speaking abilities. To be sure, the ability to forward calls exists in today's environment as well, but the technology is relatively primitive, is not always available, and, most significantly, the ability to facilitate cooperation is greatly enhanced in an IP-based environment.

In highlighting the powerful capabilities that collaboration and cooperation can provide, we champion the empowerment of PSAPs through a collaboration strategy, not a consolidation one. As explained in Part II, however, this strategy relies on the adoption of advanced technology by PSAPs and the use of mission critical applications that can tie together all relevant stakeholders as part of a "systems architecture." Where such systems are put into place, the reviews are very favorable. As Bill Buchholtz, the Executive Director of the Bexar-Metro 9-1-1 Network District in San Antonio, Texas, explained, "while talk of consolidation sparks turf wars, talk of cooperation through networking different PSAPs—and even operators from home—inspires interest and support."⁷² In Vermont, the state has taken this level of interest to the next level, tying together all ten PSAPs into a virtual system so that they can support and provide back-up services for one another.

We recognize that even the empowerment strategy we advocate here is likely to meet some resistance. After all, many PSAPs are content with their current call processing model and may lack the funding to migrate to a new technological architecture or may simply lack sophistication in modern information and communications technology and resist change on that ground. Recognizing such resistance and funding challenges, we suggest that statewide funding for a next generation systems architecture be managed at the state level and coupled with state logistical support for this transition. To be sure, local or regional PSAPs can—and some do—develop cooperative agreements on their own, but our conclusion is that a statewide commitment to forging such cooperation will result in a greater level of overall cooperation and collaboration. After all, there is no reason why individual PSAPs should own and operate individual "back office systems" when such systems can be much more affordably shared among a number of them.

In developing models for cooperation between PSAPs, it is critical

72. Telephone interview with Bill Buchholtz, Executive Dir., Bexar-Metro 9-1-1 Network Dist., in San Antonio, Tex. (June 29, 2007).

that the collaboration be structured through a well-understood model of governance. In particular, if one PSAP is taking the lead on managing the shared resource, or if a state entity is doing so, it is essential that the parties agree up-front on the relevant terms of cooperation. After all, “[e]xperiences in public sector cross-boundary collaboration demonstrate that a sound governance structure is critical to success and should not be left to chance.”⁷³ Notably, such structures will be easier to implement if they take place within the context of a state framework that calls for standardization of equipment and operating procedures, such as how operators are trained. We recognize that, even under the best of scenarios, implementing structures to facilitate cooperation will not take place without some challenges. Such challenges, however, are worth confronting to improve the quality and reliability of the 9-1-1 network as well as to save money through more effective sharing of resources.

D. The Role for the Federal Government

As suggested above, state and local governments are principally responsible for providing access to 9-1-1 from all communications technologies. To date, the federal government has sought to promote progress in access to 9-1-1 by focusing largely on only one-half of the equation—the carriers themselves. This focus has resulted largely from the fact that the FCC in particular and the federal government more generally has lacked jurisdiction over PSAPs. Nonetheless, this strategy is an unfortunate one, as discussed in Part II, because it mandates that next generation services interface with antiquated technologies used in the 9-1-1 network. Such jury-rigging often comes at considerable expense and, moreover, fails to enhance the ability of the PSAPs to receive valuable information such as data, text, images, and video services. Consequently, the federal government must also focus on the other half of the equation as well, i.e., the technological capabilities of the PSAPs and play a constructive role in supporting the development

73. NAT'L ASS'N OF STATE CHIEF INFO. OFFICERS, GETTING STARTED IN CROSS-BOUNDARY COLLABORATION: WHAT STATE CIOs NEED TO KNOW 4 (2007), available at <http://www.nascio.org/publications/documents/NASCIO-CrossBoundaryCollaboration.pdf>. As that report detailed:

A clear and representative governance model reflecting the diverse leadership among the entities that are collaborating is one of the most important first steps. Even the best intentions can fail if each organization involved is unclear which entity is spearheading the project, or if each organization thinks that it is the leading body. Developing a charter at the outset of collaboration can be a beneficial way to establish rules of engagement. Involving stakeholders at the very beginning of the project, and keeping them informed throughout the life of the collaboration, can prove to be an important asset in maintaining momentum and progress.

Id.

and adoption of new technologies.

Over the last several years, the federal government has begun to acknowledge the importance of supporting the development of a more technologically advanced E9-1-1 system. In 2004, Congress enacted the “Ensuring Needed Help Arrives Near Callers Employing 9-1-1” (“ENHANCE”) Act, which established an “E-9-1-1 Implementation Coordination Office” and authorized \$250 million per year for five years in matching grants to enhance emergency communications services.⁷⁴ Despite recognizing the value of a federal leadership role, Congress has thus far failed to appropriate these funds. Recently, however, some recent legislative efforts have sought to address this failing (at least in part) and others (notably, the H.R. 3403, 9-1-1 Modernization and Public Safety Act of 2007)⁷⁵ have sought to provide additional federal leadership on the transition to a next generation network for emergency communications. On the whole, however, the federal government has yet to commit to supporting the transition to an NG9-1-1 architecture and has enacted legislation that fails “to effectively further federal legislative purpose and policies.”⁷⁶

In short, we recommend that the federal government play a constructive role in supporting the technological progress towards an NG9-1-1 system as part of a “cooperative federalism” strategy.⁷⁷ First, the federal government should work, as the Department of Transportation (“DoT”) already is doing, in developing the basic architecture that outlines how an NG9-1-1 system would operate and why it is vastly superior to the legacy system. Going forward, however, “achieving consensus on the finer details of the architecture will be challenging and complex.”⁷⁸ To aid the federal government in this effort, the DoT has selected a number of subcontractors to develop a national architecture and transition plan, including Texas A&M University, where different solutions are being tested and trialed in an Internet Protocol-based environment. Ideally, the federal government can both demonstrate to the states the advantages of such advanced technologies

74. ENHANCE 911 Act of 2004 § 104, 47 U.S.C. § 942.

75. 9-1-1 Modernization and Public Safety Act of 2007, H.R. 3403, 110th Cong. (2007), available at <http://www.govtrack.us/congress/billtext.xpd?bill=h110-3403>.

76. James E. Holloway et al., *Regulation and Public Policy in the Full Deployment of the Enhanced Emergency Call System (E911) and Their Influence on Wireless Cellular and Other Technologies*, 12 B.U. J. SCI. & TECH. L. 93, 125 (2006).

77. For a discussion of how cooperative federalism programs work, see Philip J. Weiser, *Federal Common Law, Cooperative Federalism, and the Enforcement of the Telecom Act*, 76 N.Y.U. L. REV. 1692 (2001).

78. LINDA D. DODGE, NEXT GENERATION 9-1-1 INITIATIVE, ADDRESSING THE OPPORTUNITIES AND CHALLENGES OF TOMORROW AT THE U.S. DEPARTMENT OF TRANSPORTATION 2 (2007), available at [http://www.iacptechology.org/Communications/missioncritical3-sjr%20\(4\)%20\(3\).pdf](http://www.iacptechology.org/Communications/missioncritical3-sjr%20(4)%20(3).pdf).

as well as provide a roadmap that can facilitate their adoption.

Second, the federal government should play an active role, through agencies like the National Institute for Standards and Technology (“NIST”), the National Telecommunications and Information Agency (“NTIA”), the Department of Homeland Security, the DoT, and the FCC to support the development of the basic standards that will enable a next generation network for emergency communications to operate effectively. It is important that the specialized applications for emergency communications be developed. To do so, however, will require national leadership in terms of both vision and support for research and development. At present, there are some notable private sector efforts, including (1) an ATIS/ESIF initiative to develop standards (along with NENA) for the interconnection of all types of networks and with the emergency 9-1-1 networks⁷⁹ and (2) the Internet Engineering Task Force (“IETF”)’s focus on the use of 9-1-1 in connection with Internet-based communications.⁸⁰ Going forward, however, it will be imperative for the federal government to play a supportive role, just as they are doing in the related context of supporting the advancement of communications technologies used in public safety communications.

Finally, the federal government—through its 9-1-1 Implementation Coordination Office—should fund the grant program codified by the ENHANCE 9-1-1 Act. In taking such a step, the federal government should develop a program that benchmarks the progress of the several states and provides matching funding conditioned on, among other things, effective governance mechanisms as well as sound funding strategies, such as not engaging in raiding of E9-1-1 funds. In short, even though the states and localities will be the primary vehicle for funding the transition to next generation networks, it is clear to us that a strategic federal effort in this area would be enormously valuable in catalyzing and reinforcing such efforts.

IV. THE NEED FOR A NEW FUNDING STRATEGY

The first step in developing a new funding strategy for 9-1-1 is for

79. ATIS “is a United States based body that is committed to rapidly developing and promoting technical and operations standards for the communications” industry. ATIS Home Page, <http://www.atis.org> (last visited May 11, 2008). The Emergency Services Interconnection Forum (“ESIF”) works on standards related to emergency services. See ATIS, Emergency Services Interconnection Forum, <http://www.atis.org/esif/index.asp> (last visited May 11, 2008).

80. Comments of Cisco Sys., Inc., to the *First Report & Order & Notice of Proposed Rulemaking* in E911 Requirements for IP-Enabled Serv. Providers, WC Dkt. No. 04-36, WC Dkt. No. 05-196, 6-7 (Aug. 15, 2006), available at http://gullfoss2.fcc.gov/prod/ecfs/retrieve.cgi?native_or_pdf=pdf&id_document=6518142878.

policymakers to recognize that the provision of effective access to emergency services is a “public good” that benefits all citizens, whether or not an individual will ever call 9-1-1.⁸¹ After all, if someone is the victim of a crime, has a house burning down, or is in a car accident, another individual’s call to 9-1-1—whether from a cell phone in a car, a VoIP connection at home, or a text message—could make an enormous difference in limiting the damage to person or property. With this perspective in mind, this Part outlines the state of 9-1-1 funding.

Section A explains the more vital social function that the 9-1-1 system performs today as compared to past decades. In particular, despite the current nature of 9-1-1 as a public good, legacy approaches to funding continue to prevail. Moreover, another vestige of 9-1-1’s past involves a lack of competition. Finally, Section A discusses why NG9-1-1 systems would address this failing by facilitating innovations ushered in by a more competitive telecommunications landscape.

Section B aims to help legislators, regulators, and other relevant policymakers understand the big picture of 9-1-1 funding procedures, models, and trends. By providing a comprehensible overview, we hope to lower the barriers to the sound development of 9-1-1 policy. Notably, existing 9-1-1 funding policies are “complicated by the lack of understanding on how funding is collected and dispersed”⁸² and, as a result, complexity is itself a barrier to sound and principled policymaking. To address this problem, we diagram the prevailing methodology by which 9-1-1 funds are collected, remitted, allocated, and ultimately used. To be sure, our goal of making 9-1-1 funding comprehensible entails trade-offs; foregrounding some aspects necessarily requires backgrounding other details. Nonetheless, we believe that an accessible

81. As one report stated, today’s 9-1-1 usage “meets the non-rivalry and non-excludability tests, frequently used to define public goods, and it is used in many circumstances to report incidents that relate to the safety of the public as opposed to the caller.” MONITOR GROUP REPORT 1, *supra* note 55, at 11. Indeed, the Monitor Group Report found that “in more than 60 percent of all 9-1-1 call situations, the caller is not involved in the emergency being reported.” *Id.* at 68. A public good is defined as:

a very special class of goods which cannot practically be withheld from one individual consumer without withholding them from all (the ‘nonexcludability criterion’) and for which the marginal cost of an additional person consuming them, once they have been produced, is zero (the ‘nonrivalrous consumption’ criterion). The classic example of a nearly pure public good is national defense: you cannot defend the vulnerable border regions of a country from the ravages of foreign invaders without also simultaneously defending everyone else who lives within the borders.

Auburn University, Dr. Paul M. Johnson, Public Goods: A Glossary of Political Economy Terms, http://www.auburn.edu/~johnspm/gloss/public_goods (last visited May 11, 2008).

82. NGA CENTER FOR BEST PRACTICES, ISSUE BRIEF: STATE STRATEGIES FOR ACCELERATING ENHANCED 9-1-1 IMPLEMENTATION 4 (2004) [hereinafter NGA ISSUE BRIEF], <http://www.nga.org/cda/files/0404E911.pdf>.

discussion of 9-1-1 funding is worthwhile.

Section C, building off our findings and research, distills a series of five normative recommendations that federal, state, and local policymakers should consider in charting 9-1-1 policy going forward. We emphasize that, in addition to funding amounts for 9-1-1, policymakers must pay close attention to broader issues related to funding, including procedures for the collection of funds, allocation and usage of funds, and auditing and monitoring of all parties involved in the 9-1-1 system. Moreover, Section C discusses the issue of how to evaluate the sufficiency of existing 9-1-1 funding level, recommending as a critical prerequisite the development of a statement of requirements that can enable policymakers to discern whether existing funding levels and mechanisms are sufficient to support the development and migration to such a system. In so doing, it highlights that policymakers should focus both on preserving existing 9-1-1 systems and in developing new funding models to facilitate the transition to NG9-1-1 systems (including strategies for financing capital expenditures).

A. The Importance of Understanding That 9-1-1 Is a Public Good and Innovation Should Be Promoted

As a practical matter, the United States has not always viewed an effective and ubiquitous emergency network as a core social value. Notably, the United States adopted 9-1-1 approximately 30 years after England implemented a similar 9-9-9 system.⁸³ Even when implemented in the late 1960s, when it was clear that 9-1-1 capability would be offered by the Bell System Companies, the emergency calling system was “not mandatory” and would only be “implemented where the emergency agencies in a community are willing to cooperate with each other.”⁸⁴ Thus, by 1987, only 50% of the United States population had access to 9-1-1.⁸⁵ The relatively slow pace of adoption reflects the fact that 9-1-1 wireline-based funding models largely developed during a time when 9-1-1 service was local, optional, and primarily benefited residential phone owners who were served by a regulated monopoly local exchange carrier.⁸⁶ Not surprisingly, legacy funding mechanisms

83. Letter from Lee Loevinger, *supra* note 1.

84. *Id.*

85. Positron Public Safety Systems, Powerpoint on Behalf of Qwest, at 1, http://www.911dispatch.com/911/ng911_qwest.pdf (last visited May 11, 2008).

86. Another forward-looking report sounds a similar note: “The current funding model for 9-1-1 service has its foundation in the historic regulated wireline telecommunications environment of the past 30 years.” NAT’L EMERGENCY NO. ASS’N, FUNDING 9-1-1 INTO THE NEXT GENERATION: AN OVERVIEW OF NG9-1-1 FUNDING MODEL OPTIONS FOR CONSIDERATION 3 (2007) [hereinafter NENA NG9-1-1 FUNDING REPORT], <http://www.nena.org/media/files/NGFundingReport.pdf>.

reflected these characteristics. With the rise in wireless telephony, policymakers turned to new funding models developed in the late 1990s and early 2000s to help achieve Phase I and II compliance goals.

Even today, contemporary funding models often reflect the legacy tradition of the telephone monopoly past: fragmented and local-centric approaches that remain heavily dependent on inputs such as user surcharges or costs borne by service providers. Meanwhile, the number of players involved in the 9-1-1 system has ballooned in the wake of local competition introduced by the 1996 Act and an expanding range of communications services. For example, competition in the local exchange telephony market introduced Competitive Local Exchange Carriers (“CLECs”) to 9-1-1 funding obligations. And the proliferation of innovative telecommunications technologies and services—mobile phones, VoIP devices, pre-paid wireless phones, etc.—added several more types of service providers into many jurisdictions’ 9-1-1 funding schemes. Finally, while 9-1-1 remains closely tied to local government services, its larger public safety and homeland security impacts have accelerated state and federal government interest in 9-1-1.

With the increased use of 9-1-1 services and its now-central role in promoting public safety, most citizens expect calls to 9-1-1 to operate effectively and to be able to take advantage of modern technologies. One industry source colorfully referred to heightened consumer expectations of technology as “the *CSI* effect”⁸⁷ and confirmed that proprietary industry surveys have reached the same conclusion.⁸⁸ As another report put it, “the perception of 9-1-1 service by the public has changed from an optional service to an expected public good.”⁸⁹ Significantly, approximately 99% of the population and 96% of the geographic United States now have access to at least basic 9-1-1 services.⁹⁰ In short, the value of 9-1-1’s contributions to society is qualitatively different today

87. *CSI*—short for Crime Scene Investigation—is a popular television show in which crimes are regularly solved by use of technology resources and forensic science. The show’s popularity has generally raised public expectations of technology capabilities. See, e.g., *The CSI Effect: Does The TV Crime Drama Influence How Jurors Think?*, CBS NEWS, Mar. 21, 2005, available at <http://www.cbsnews.com/stories/2005/03/21/earlyshow/main681949.shtml>.

88. Survey data shared by the industry source empirically underscores the chasm between public expectations and 9-1-1 capabilities. A Spring 2007 survey of 2,580 individuals in the United States found that almost 40% of individuals under 35 years old believe that they “can use a text message from a cell phone to summon 9-1-1” and, additionally, over 30% of the same group believes that they “can send a cell phone picture to 9-1-1.” INTRADO INC., CONSUMER 9-1-1 RESEARCH (2007) (on file with author).

89. VOIP OPERATIONS FUNDING WORK GROUP OF THE VOIP OPERATIONS COMM., NAT’L EMERGENCY NO. ASS’N, NENA VOIP FUNDING AND REGULATORY ISSUES OPERATIONAL INFORMATION DOCUMENT 5 (2006) [hereinafter NENA VOIP OID REPORT], available at <http://www.nena.org/media/files/VoIPNENAFundingRegulatoryOIDfinal060606.pdf>.

90. E9-1-1 Institute, *The Issues*, *supra* note 2.

than during the period when traditional 9-1-1 funding models developed and, accordingly, the elevated societal value of 9-1-1 cannot be ignored.

The levels of 9-1-1 funding, the mechanisms for fund collection, and the usage of the relevant funds fail to reflect the modern reality that 9-1-1 is more valuable and critical now than it was at earlier stages of the system's development. In particular, the qualitatively different value of the 9-1-1 system today than when it was developed provides urgency for federal, state, and local policymakers to evaluate whether their existing 9-1-1 funding strategy will accomplish two fundamental objectives: (1) meeting the needs of citizens who expect uniform and reliable 9-1-1 service across jurisdictional boundaries, across communication devices, and across different communication services; and (2) promoting public safety and homeland security by closing the chasm between E9-1-1 public safety capabilities (often limited to analog voice) and the capabilities of commercial communications systems (often IP-based systems that are capable of carrying voice, data, text, image, and video services).

To ensure that it meets its objectives, we recommend a strategy for 9-1-1 that would harness the competitive forces that drive innovation in other sectors of telecommunications. Despite widespread industry deregulation favoring competition over the last 25 years—first, around the break up of AT&T and, second, arising out of the 1996 Telecom Act—significant portions of today's 9-1-1 system remain a *de facto* monopoly in most jurisdictions. In particular, as one company's white paper laments: “[R]egulation of 9-1-1 networks and related services remains firmly rooted in a regionalized monopoly model in which 9-1-1 call routing, switching, transport, and database management services have been the exclusive domain of the incumbent local exchange carrier (ILEC).”⁹¹

To be sure, the historic success of the 9-1-1 system is to be applauded and the CAMA technology leveraged by the Bell System and subsequent incumbent providers once served the country well. It is clear, however, that the ongoing monopoly-era style regulation of incumbent 9-1-1 service providers should be reevaluated. To that end, state officials, carriers, and would-be competitive providers commonly pointed to a lack of innovation incentive on the part of 9-1-1 service providers. Consequently, even though some vendors and would-be competitive 9-1-1 service providers are eager to move to an NG9-1-1 system, incumbent 9-1-1 service providers (“9-1-1 SPs”) are unlikely to champion an upgrade absent regulatory change.

91. INTRADO COMMCS, INC., 9-1-1 NETWORKS IN THE 21ST CENTURY: THE CASE FOR COMPETITION 2 (2007).

In order to understand the opportunity for reforming the 9-1-1 system, policymakers must examine the current incentives of incumbent 9-1-1 SPs. Overall, incumbents often view 9-1-1 services not as a profit center, but as a social obligation with minimal room for profits. Indeed, one carrier insider observed that 9-1-1 services—originally provided as part of a monopoly’s regulatory compact—are not a market that many incumbent 9-1-1 SPs would actively seek today. Significantly, an incumbent 9-1-1 SP typically provides services at tariffed prices which are approved by regulators at amounts that permit the recovery of their costs plus a rate of return. To help establish lower rates, regulators often require long amortization periods for incumbent 9-1-1 SPs’ facilities.⁹² This creates strong incentive to continue to collect on existing if aging network elements, i.e., to capture past costs and collect ongoing profits, resulting in a limited incentive to innovate.

In some instances, incumbent 9-1-1 SPs’ failure to upgrade effectively blocks innovation and serves as a bottleneck that traps architectural improvements to the system. In particular, at least two forms of bundled offerings from 9-1-1 SPs frustrate competition and stifle innovation. From the PSAP’s perspective, a state official noted that incumbent 9-1-1 SPs’ network and equipment are frequently offered to PSAPs as a bundled package, and the network provider then uses its position to prevent deployment of other networks. From the perspective of other carriers and potential competitors, a 9-1-1 SP often bundles its offerings into a single package, forcing would-be competitors to purchase duplicative and rival services in order to receive necessary access to a PSAP.

Significantly, the migration to an NG9-1-1 system promises a path to reforming the legacy monopoly model. To highlight the nature of that change, we return to Figure 7’s tripartite representation of the 9-1-1 system (reproduced below).

Figure 7: Elements of a NG9-1-1 System

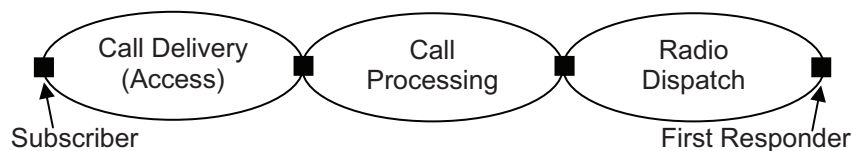

In today’s system, the selective router is located within the first

92. *Id.* at 7.

portion (Call Delivery) of the above sequence such that an incumbent 9-1-1 SP typically possesses a powerful bottleneck that requires interconnection and interoperability by would-be competitive 9-1-1 SPs. In the NG9-1-1 system, however, the *selective router functionality*⁹³ can be placed directly where a call is handed off from the access network to the call processing network. By placing the selective router functionality at the outset of the call processing portion of the system, there is opportunity to help relieve the traditional incumbent bottleneck and introduce greater competition into the system. More generally, an NG9-1-1 architecture should enable the 9-1-1 network to be managed in a more modular fashion, with clearer demarcations between responsibilities for call delivery, call processing, and radio dispatch. This will provide more opportunities for competitive supply of the different elements of the system. Accordingly, in contrast to the current model, we believe that this transition to a more open and competitive system will introduce opportunities and incentives to innovate that do not exist under and are greatly limited by today's antiquated technological architecture.⁹⁴

B. The Current System of Collecting, Remitting, Allocating, and Using 9-1-1 Funds

Much is misunderstood about the world of 9-1-1 funding. This is not surprising as 9-1-1 funding is often a complicated matter within individual states, and the myriad different approaches taken by different jurisdictions collectively creates a convoluted picture for policymakers and legislators who are not closely familiar with the area.

This Section aims to reduce this confusion. To do so, we divide the funding process into four parts: a *collection stage* (what amounts marked for 9-1-1 are collected and from what services?), a *remittance stage* (what agency(ies) do service providers remit amounts collected for 9-1-1?), an *allocation stage* (once 9-1-1-related proceeds have been remitted to an agency, to which entities do collected monies go prior to

93. By "selective router functionality," we mean to distinguish the selective router *function* from the actual devices which we today commonly refer to as "selective routers." In the Internet Protocol world, the functionality of the selective router will not be performed by one of today's selective routers, but instead will be performed by a device that simply accomplishes that function. (The terminology here is somewhat confused by the fact that the original selective router was itself a switch—not a router. In any event, when the *functionality* is moved to an Internet Protocol network, we anticipate that NG9-1-1 networks will actually use a device properly called a router).

94. As a general matter, Harvard's Berkman Center makes a strong case for open systems which facilitate competition and interoperability. Policymakers should consider this broader perspective in adopting NG9-1-1 standards and requirements. See BERKMAN CENTER FOR INTERNET & SOCIETY, ROADMAP FOR OPEN ICT ECOSYSTEMS 9-10 (2005), available at <http://cyber.law.harvard.edu/epolicy/roadmap.pdf>.

being spent?), and a *usage stage* (i.e., once an entity has 9-1-1 funds for expenditure, how are such monies used?). This description is set forth in Figure 9 below.

Figure 9: Four stages of 9-1-1 funding

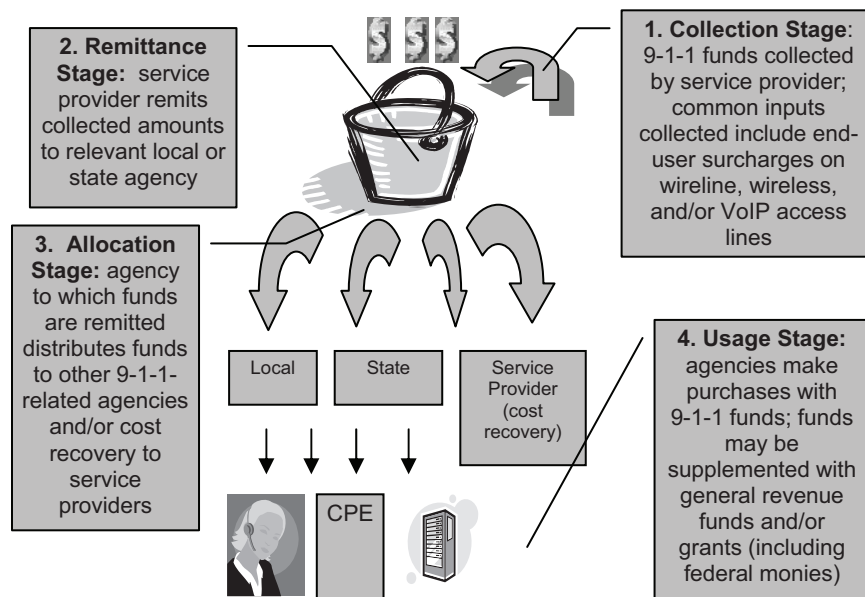

We recognize that this depiction is a simplification and that these four stages are not always present. For example, sometimes a governmental entity to which funds are remitted also determines how such funds will be used. Under these circumstances, the remittance stage is effectively combined with allocation. As we shall see, however, it is often the case that—following remittance to an entity—9-1-1 monies are first routed to a different government entity prior to final usage, making the four stage approach a more effective way to understand 9-1-1 funding.

1. 9-1-1 Fund Collection

Sources for 9-1-1 funding vary along vertical levels of government (e.g., municipality, county, regional, state, and federal). In general, there are four principal funding sources that support 9-1-1: (1) direct end-user surcharges; (2) state-level general funding sources (which ultimately flow from taxes); (3) local, county, or regional-level funding sources (such as proceeds from gross receipts taxes or property taxes); and (4) federal funding sources (especially grant initiatives). Among these sources, the most common and dedicated funding source for 9-1-1 services is end-

user surcharges, where an amount is directly assessed to telephony services to help pay for 9-1-1-related costs. As reflected in Figure 10 below, there are at least three salient dimensions to surcharges.

Figure 10: Important Considerations Concerning 9-1-1 Surcharges

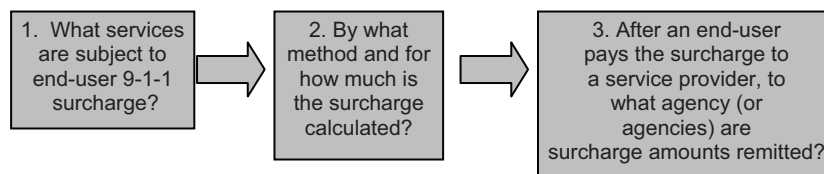

With respect to the first dimension of Figure 10, whether a 9-1-1 surcharge is assessed depends on the communications service involved and the jurisdiction. Not surprisingly, as the legacy model of 9-1-1 funding, end-user surcharges are almost always assessed on wireline telephone connections. Additionally, surcharges on wireless calls are increasingly common: 47 states permit wireless surcharge. Finally, VoIP surcharges are present in 15 states.⁹⁵ Moreover, even for jurisdictions which do not yet mandate that VoIP assess 9-1-1 surcharges, our interviews found that VoIP providers have often reached voluntary agreements with local or regional entities to pay the equivalent of 9-1-1 surcharges.

With respect to the second dimension of Figure 10, two prevailing methods of calculation, flat fee or percentage, are utilized. Most jurisdictions require a flat fee payment into 9-1-1 funds, although at least six states use a percentage formula to determine wireline fees. Under a flat fee method, irrespective of the amount of use, each user of the telephone service in the same jurisdiction pays an equal amount as each other user into the 9-1-1 fund. For example, in Newark, New Jersey, a wireline telephony user pays 90¢ per month. Similarly, a wireless telephony user in Newark also pays 90¢ per month. It is not always the case, however, that wireline and wireless surcharges are uniform in a jurisdiction. In Kentucky, for example, a wireless user pays 70¢ per month while a wireline user pays 25¢ per month. In contrast, other end-user surcharges are assessed on a percentage basis. For example, in Louisiana, wireline users pay up to 5% of tariffed rates for local telephone basic service.

End-user surcharges amounts vary considerably between different

95. Vermont is unique insofar as it uses Universal Service Fund proceeds for E9-1-1 funding. Moreover, all statistics and amounts cited in this Part IV.B are based on research as of October 2007.

jurisdictions. Wireline surcharges range from 25¢ per month to \$3 per month; wireless surcharges range from 20¢ per month to \$3 per month. While this variation between jurisdictions is perhaps surprising on its face, end-user surcharges cannot be examined in isolation. Although the end-user surcharge is significant, it is only one potential input into 9-1-1 funding. Accordingly, an apples-to-apples comparison concerning amounts of 9-1-1 funding between jurisdictions must comprehensively look at end-user surcharges in combination with other categories of funding sources such as state-level general funding sources, local funding, and federal grants.

2. Remittance of 9-1-1 Funds

As to the third dimension of Figure 10 above, monies are usually remitted to a government agency after they are collected by a service provider. In some cases, a service provider is entitled to keep a percentage of the collected funds as an administrative fee, such as in Tennessee where wireless providers retain 3% of collected amounts. As for the remitted funds, they typically go to a local or state-level entity. Notably, local agencies receiving the 9-1-1 monies can vary among government entities lower than the state level (municipal, city, county or regional). Similarly, the state agency to which 9-1-1 monies are remitted vary as well and may include a state-level 9-1-1 board, a treasury office, or a public utilities commission.⁹⁶

The traditional model of 9-1-1 surcharges featured a monopoly local service provider remitting funds into a local agency. This model still remains the prevailing approach today, but the trend is toward greater involvement of state entities in the remittance stage. Indeed, at least 20 states now have a funding scheme which features a significant state role whereby 9-1-1 wireline surcharges are remitted to the state agency. Moreover, all but eleven states have wireline, wireless, or both types of carriers remit funds to a state agency. Finally, several states have a hybrid solution where some amounts are remitted to a state agency while others are paid into local entities.

Consider, for example, Washington State as an illustration of a hybrid approach. In Washington, 25¢ of wireline and wireless fees are paid to a state-level entity while 50¢ of wireline and wireless fees go to county entities. This type of division is hardly unique as our research indicates that 20 states currently have a hybrid approach to collection in place where at least some carriers remit to state entities while the same or other carriers remit to local agencies. As elaborated upon in Section B, we suggest that in order to promote administrative efficiency and

96. See GAO STATES' COLLECTION REPORT, *supra* note 54, at 16.

fairness, states should migrate toward a unified state-level collection process where surcharges are in place.

3. Allocation of 9-1-1 Funds

The allocation stage is a crucial one: once 9-1-1-funds are collected, they are frequently distributed to other governmental entities prior to the point in which monies are used for purchases and expenditures. Sometimes the collecting entity is also the purchasing entity, in which case the allocation stage is effectively combined with the remittance stage. A more common scenario, however, entails shifting around the 9-1-1 related funds prior to usage.

For an example of that scenario, consider the model used by the Tennessee Emergency Communications Board (“TECB”). The TECB was formed in 1998 to promote wireless E9-1-1 services as well as assist local entities known in Tennessee as Emergency Communications Districts (“ECDs”) on management, operations, and accountability matters.⁹⁷ Moreover, it is also empowered to oversee the state’s 9-1-1 Emergency Communications Fund (“9-1-1 ECF”). To support this fund, wireless carriers collect \$1 per month surcharges that are remitted once every two months to the 9-1-1 ECF, subject to 3% which the carrier keeps as an administrative fee.

The TECB allocates the relevant funds through a complex system.⁹⁸ First, 25% of the total fund is distributed to ECDs based on district’s proportion of total population. Second, the TECB uses the fund to pay its own operating costs and expenses. Third, ECDs are reimbursed for expenditures related to implementation, operation, or enhancement of wireless E9-1-1. Fourth, wireless service providers are reimbursed for expenditures related to implementation, operation, or enhancement of wireless E9-1-1. Fifth, if there are still unspent funds, they may be used by the TECB to provide for grants to ECDs related to operating and capital expenditures. Finally, once wireless E9-1-1 is achieved, the TECB must distribute funds back to ECDs if the TECB believes that such distribution will not threaten the solvency of the 9-1-1 ECF.

As suggested by the Tennessee example, an important aspect of the allocation stage concerns the formulas by which funds remitted to an agency are in turn allocated. A variety of methods are used in determining which entity is entitled to a given amount of money,

97. See TENNESSEE ADVISORY COMMISSION ON INTERGOVERNMENTAL RELATIONS, EMERGENCY CHALLENGE: A STUDY OF E-911 TECHNOLOGY AND FUNDING STRUCTURE IN TENNESSEE 72 (2006) [hereinafter TACIR E-911 STUDY], available at http://www.state.tn.us/tacir/PDF_FILES/Other_Issues/E911%20funding.pdf.

98. *Id.* at 67-68.

including the population of an area for which the entity is responsible, an entity's prior expenses, call volume, and an entity's prospective budget requests. For example, Virginia recently changed its Wireless E9-1-1 Fund allocation scheme from one based on projected costs to a formula-based method. Under Virginia's new approach to allocation of its Wireless E9-1-1 Fund, monies are initially provided to the Division of Public Safety Communications and Virginia Geographical Information Network Division, reducing the amount of the Wireless E9-1-1 Fund. Following this, the remaining amount in the Wireless E9-1-1 Fund is allocated as follows: (1) 30% is allocated to wireless service providers for cost recovery related to direct and reasonable costs for wireless E9-1-1 network deployment; (2) 60% is allocated to localities for PSAP's recurring and non-recurring costs; and (3) 10% is allocated to a grant program (to be implemented largely in 2008), whereby monies will be allocated to localities with the most need.⁹⁹

As seen in Tennessee and Virginia, jurisdictions sometimes permit cost recovery of service provider expenses, especially those of wireless carriers, related to providing 9-1-1 services. While some jurisdictions seem to have success with cost recovery programs, the concept of cost recovery has an uneven record at best. Indeed, even where it is available, cost recovery is not always utilized by commercial wireless carriers. While the FCC initially required cost recovery in 1996 to promote wireless E9-1-1 build out, it lifted that requirement in 1999.¹⁰⁰ Nonetheless, many jurisdictions continue cost recovery programs in the absence of the requirement.¹⁰¹ Based on our interviews, however, we concluded that many wireless carriers eschew utilization of the cost recovery mechanisms for at least two reasons. First, as a GAO report noted in 2003, wireless carriers "might not seek to recoup costs incurred with deploying E911 if they plan to use the location technologies for

99. VIRGINIA INFORMATION TECHNOLOGIES AGENCY, DIV. OF PUB. SAFETY COMM'NS, COMMONWEALTH OF VIRGINIA: WIRELESS E9-1-1 SERVICES BOARD FY2006 ANNUAL REPORT 6 (2006) [hereinafter VIRGINIA WIRELESS E9-1-1 2006 ANNUAL REPORT], *available at* http://www.911.virginia.gov/wirelessreports/FY2006_Annual_Report.pdf. As to the grant program, funds are available for "continuity" grants which help maintain existing PSAP services as well as "enhancement" grants focused on improving E9-1-1 services. *Id.*

100. Revision of the Commission's Rules to Ensure Compatibility with Enhanced 911 Emergency Calling Sys., *Second Memorandum Opinion & Order*, 14 FCC Rcd. 20,850, 20,911 (1999).

101. Indeed, as of 2003, the GAO reported that 32 states and the District of Columbia continued to provide some form of cost recovery. U.S. GEN. ACCOUNTING OFFICE, UNEVEN IMPLEMENTATION OF WIRELESS ENHANCED 911 RAISES PROSPECT OF PIECEMEAL AVAILABILITY FOR YEARS TO COME 19-20 (2003), *available at* <http://www.gao.gov/new.items/d0455.pdf>.

commercial purposes.”¹⁰² Second, some wireless carriers find it difficult to recover costs for reasons either related to administrative burden or incomplete recovery and instead elect to directly charge customers a fee to help pay for wireless E9-1-1.

Amounts allocated to state and local agencies for 9-1-1 are supplemented by other funding sources, including state level funds, local sources, and federal grant and matching programs. These sources of funding are further discussed in Part IV(C) below.

4. Usage of 9-1-1 Funds

The fourth and final funding stage, usage, concerns an agency's expenditure of 9-1-1-related funds. Given the critical public function performed by 9-1-1 services with limited resources, care should be given to ensure that 9-1-1-related funds are used for their intended purposes. So long as surcharges continue to play a central role in 9-1-1 funding,¹⁰³ policymakers owe an obligation to consumers to ensure that monies earmarked for 9-1-1 are actually used for 9-1-1.¹⁰⁴ In many cases, the relevant problem is the diversion of 9-1-1 funds to other uses—i.e., the so-called “raiding” of 9-1-1 funds. In some other cases, however, the problem is that even though the 9-1-1 funds are used for legitimate purposes, they are used to support “gold-plated” infrastructure that cannot be justified as a prudent investment.

A well documented parade of horrors underscores that 9-1-1 funds are often seized for purposes that have little or nothing to do with the services which are required to pay into 9-1-1 funds.¹⁰⁵ Indeed, Congress explicitly addressed raiding in passing the 2004 ENHANCE 9-1-1 Act, which tied distribution of federal grants to the requirement that 9-1-1 funds be used only for 9-1-1-related expenditures. Unfortunately, the 2004 Act has not been funded and this carrot has had little effect on states to date. Our research and interviews confirmed that raiding in various forms today remains a pervasive and endemic problem.

102. *Id.* at 20 n.22.

103. Over the long term, a migration to other funding models may be necessary in view of industry trends which render uncertain an enduring reliance on the surcharge funding model. *See, e.g.*, NENA NG9-1-1 FUNDING REPORT, *supra* note 86, at 3. Moreover, since 9-1-1 benefits the general public and far more individuals than just the owners of telephony devices, a greater general funding commitment would reflect sound policy. A challenge, however, is to migrate to new funding models which prove reliable and adequate in amounts. As industry players have opined to us, one salutary effect of the current funding model is that today's system presents dedicated support for 9-1-1 that is at least to some degree reliable.

104. In addition to on-going examination of agencies' use of funds, future attention is warranted concerning use of funds collected by ILECs for provision of E9-1-1 services. Particularly where aged equipment is largely depreciated and cost allocation/auditing studies are lacking, such a study could determine whether such funds are well used.

105. *See* GAO STATES' COLLECTION REPORT, *supra* note 54, at 16-18.

Raiding is not just a problem from the perspective of supporting 9-1-1, but also from a fiscal policy perspective because the bulk of 9-1-1 funding does not come from general public coffers. Significantly, so long as large portions of 9-1-1 services are effectively supported by industry-specific assessments, jurisdictions should be parsimonious concerning the scope of permitted expenditures drawing upon these funds. After all, communications services are valuable social goods that should not be deterred by unnecessary added costs that distort and reduce the use of these services. It is one thing to expect wireless carriers and their customers to pay for elements and costs that they arguably impose upon the 9-1-1 system in order to make Wireless E9-1-1 Phase II possible. It is another matter, however, to use wireless surcharges to fund law enforcement uniforms, which have little or no direct nexus with the wireless services being assessed.¹⁰⁶

Indeed, when monies from surcharges are raided for non-9-1-1 purposes, there are at least four pernicious effects: (1) a weakened 9-1-1 system because dedicated 9-1-1 resources are used elsewhere; (2) compromised government credibility as monies collected under government authority are used for purposes different than stated for collection; (3) an unfairness to providers and their subscribers insofar as they involuntarily pay for public services that have little nexus to the services which are assessed; and (4) unnecessary economic inefficiency because optimal consumer use of the assessed communication services is deterred by higher than necessary surcharges on those services.

It is critical that policymakers become more active in identifying raiding and, once spotted, more vigilant in preventing it. Despite the barbarian overtones of the “raiding” nomenclature, the practice of raiding is not always overt and can be difficult to identify. Nonetheless, our research identified at least three types of raiding that policymakers should guard against: (1) a blatant fund sweep; (2) continued funding of a completed project; and (3) misuse of funds. We address each point below.

First, a blatant fund sweep is the easiest flavor of raiding to identify. 9-1-1 monies in state or local coffers are swept away and put to general uses such as balancing governmental budgets or uses entirely unrelated to public safety. A 2006 GAO report identified four states—Rhode Island (\$9 million), North Carolina (\$25 million), Virginia (\$4.7 million) and

106. Daryl Bassett of the Arkansas Public Service Commission recently echoed this perspective. “If you’re going to tax a consumer for E911, the consumer should have a reasonable expectation that the money is going to be spent on E911. Too many local governments look at that as an income stream” and spend it elsewhere. Panel discussion, CTIA Wireless I.T. & Entertainment (Oct. 2007) (reported by Brian Hammond) (on file with author).

Illinois (\$254,000)—that raided wireless funds for other uses in 2005, and seven states that did not respond to questions concerning raiding.¹⁰⁷ Prior to that, a 2003 report pegged an estimated diversion of 9-1-1 funds between 2001 and 2004 at over \$400 million.¹⁰⁸ In California alone, a 2004 State audit found that from 1981-2002, almost \$177 million had been transferred to the State's general fund but only \$25 million had been transferred back, a net raid of approximately \$152 million.¹⁰⁹ Moreover, a new law in North Carolina appears to virtually legislate raiding.¹¹⁰ Under the law, monies in individual PSAP's Emergency Telephone System Funds as of the effective date, January 1, 2008, will be transferred to the local government's General Fund "to be used for any lawful purpose."¹¹¹ Collectively, the amount involved is estimated to be between \$5.5 and \$6 million.¹¹²

Second, a more subtle version of raiding involves continued funding of a completed project in which a project that begins as an appropriate use of 9-1-1 monies continues past its intended completion. For example, the Virginia State Police originally and properly received allocations from Virginia's Wireless E9-1-1 Fund to compensate for directly taking wireless E9-1-1 calls. It is no longer the case, however, that the Virginia State Police directly takes such calls. Nonetheless, under the State's Appropriations Act for 2006-08, the Virginia State Police continues to receive \$3.7 million despite the fact that the "original justification for providing the funding to the State Police" has been obviated.¹¹³ Not surprisingly, this effectively "reduces the amount of funding available to the PSAPs and wireless service providers."¹¹⁴

And third, another less visible version of raiding involves misuse of funds where, while not blatantly raided, 9-1-1 monies are nonetheless diverted for uses with only a tenuous nexus to the original justification

107. GAO STATES' COLLECTION REPORT, *supra* note 54, at 18. Similarly, a 2005 Congressional Research Service report listed numerous instances of reported diversions cited in a 2003 CTIA report, including a reported \$207 million diverted in New York, \$7 million in Oregon, and \$9.45 million in Washington D.C. See LINDA K. MOORE, CONG. RESEARCH SERV., AN EMERGENCY COMMUNICATIONS SAFETY NET: INTEGRATING 9-1-1 AND OTHER SERVICES (2005), available at <http://www.fas.org/sgp/crs/homsec/RL32939.pdf>.

108. MONITOR GROUP REPORT 1, *supra* note 55, at 11.

109. CALIFORNIA STATE AUDITOR, WIRELESS ENHANCED 911: THE STATE HAS SUCCESSFULLY BEGUN IMPLEMENTATION, BUT BETTER MONITORING OF EXPENDITURES AND WIRELESS 911 WAIT TIMES IS NEEDED 63 (2004), available at <http://www.bsa.ca.gov/pdfs/sr2006/2004-106.pdf>.

110. Glenn Bischoff, *Sadly, It's Still Business As Usual*, MRT BULL., Oct. 5, 2007, http://enews.penton.com/enews/mobileradiotech/mrt_bulletin/2007_10_06_mrt_bulletin_10062007/display.

111. *Id.*

112. *Id.*

113. VIRGINIA WIRELESS E9-1-1 2006 ANNUAL REPORT, *supra* note 99, at 2.

114. *Id.* at 5.

for their collection.¹¹⁵ For example, in Oregon in 2007, an effort was made to use \$9 million of 9-1-1 tax revenue to fund wireless communication interoperability planning and engineering activities. While we agree that public safety interoperability presents an important and laudable objective,¹¹⁶ the Oregon bill (SB 994) presents exactly the type of diversion of 9-1-1 funds to a general public benefit for which there is little direct nexus with the communications services being assessed. Accordingly, Oregon's Governor, Theodore Kulongoski, acted properly in vetoing the bill.¹¹⁷

Another recent instance of misuse is found in Cabell County, West Virginia. In August 2007, that county indicated its intention to move forward with a plan to use money from the County's 9-1-1 and Emergency Medical Service agencies to fund the bulk of a courthouse pay raise. In so doing, it offered a highly tenuous rationale, reporting that the funds would be used to "help the county recoup costs associated with courthouse employees furnishing [public safety] agencies with human resource, legal, purchasing, accounting, and payroll services."¹¹⁸ In this same vein, a North Dakota performance audit reported that a "number of PSAP locations were unable to justify the use of 911 fees for

115. At first, it is tempting to recommend wide-spread use of sunset provisions to guard against continued funding of a completed project. However, caution should be exercised in connection with such legislative provisions. Sunsets can be especially problematic when 9-1-1 goals are unmet at the end of the prescribed period and legislation comes up for renewal. For example, Ohio's HB361 is ready to sunset despite achieving limited success concerning Phase II deployment. In general, a more sound solution to guard against gratuitous funding of a completed project is to require "look back" provisions whereby an audit or report must be issued to the legislature within a prescribed period of time. See NENA OHIO CHAPTER AND APCO OHIO CHAPTER, POSITION PAPER: SUPPORTING THE REMOVAL OF THE "SUNSET" PROVISION CONTAINED IN OHIO HOUSE BILL 361 at 2 (2007), available at <http://www.ohioapco.org/911goestocolumbus/positionpaper.pdf>.

116. See, e.g., DALE N. HATFIELD & PHILIP J. WEISER, A NEW VIEW: DEVELOPING A WORKABLE NEXT-GENERATION NETWORK FOR PUBLIC SAFETY MEANS RETHINKING ENTRENCHED IDEAS AND LOOKING TOWARD A FUTURE ROADMAP (2007), available at <http://www.siliconflatirons.org/documents/publications/policy/HatfieldWeiserPublicSafetyReport.pdf>; BRAD BERNTHAL, STEVE ROBERTSON & JUSTIN TURNER, COLLABORATIVE NETWORKS AND THE ALASKA LAND MOBILE RADIO SYSTEM: A FRAMEWORK FOR ANALYZING INTER-AGENCY PEOPLE PROBLEMS WHICH FRUSTRATE PUBLIC SAFETY INTEROPERABILITY (2007), available at <http://www.siliconflatirons.org/documents/publications/faculty/BernthalRobertsonTurnerCollaborativeNetworks.pdf>.

117. In a statement, Governor Kulongoski explained: "I have vetoed the transfer of \$9 million because it is important that funds collected from telecommunications customers for enhancements to the 9-1-1 emergency response system to be used for the purposes established in the applicable statutes." Press Release, Or. Governor's Office, Governor Kulongoski Issues Vetoes for 2007 Legislative Session (Aug. 9, 2007), available at <http://listsmart.osl.state.or.us/pipermail/comm-council/2007-August/000814.html>.

118. Curtis Johnson, *PSC Attorney Sidesteps Cabell 911 Administrative Fee*, HERALD DISPATCH, Aug. 23, 2007.

PSAP operations,” and that improper uses included placement of Christmas/holiday greeting ads in newspapers and sponsorship of activities such as fire prevention, domestic violence, and farm safety.¹¹⁹

C. Five Policy Recommendations for 9-1-1 Funding Going Forward

This Section distills five recommendations related to 9-1-1 funding based on our interviews, additional research, and analysis. At the outset, we readily acknowledge that one size does not fit all in 9-1-1. For example, a recommendation that fits well in Colorado may be ill-advised, politically untenable, and perhaps contrary to existing law in Kentucky. That said, on balance we envision and encourage increased standardization and adoption of best practices across jurisdictions as 9-1-1 continues its migration from an analog fixed telephone service into a digital world characterized by mobility and diverse types of communication services. The following recommendations related to 9-1-1 funding aim to promote such a development.

1. 9-1-1 Services Must Be Better Aligned with the Expectations and Demands of Consumers and Citizens

The historic success of the 9-1-1 system combined with aspects of current analog infrastructure is the source of a gulf between consumer assumptions about the system’s robust capabilities and the system’s actual limitations. We found this to be a recurring theme acknowledged throughout our interviews and research. In considering 9-1-1 funding, consumer and citizen expectations should drive policymakers to adopt funding models which meet public demands concerning emergency services.

Specifically, there are three respects in which 9-1-1 system performance currently fails to match consumer expectations. First, consumers expect consistent 9-1-1 service across municipal, county, and state jurisdictions. In contrast, the legacy 9-1-1 model yields an erratic patchwork where crossing a county line may mean the difference between Phase II location capability and no 9-1-1 service at all. Consumers that pay the same amount in different parts of a state reasonably expect comparable 9-1-1 service across jurisdictions or at least receive a fair share of 9-1-1 service where their costs of service are higher. Second, consumers expect consistent 9-1-1 service across different communications technologies. “Consumers are generally unaware of the

119. NORTH DAKOTA STATE AUDITOR, PERFORMANCE AUDIT REPORT: 911 FEES — COLLECTION AND USE 12-13 (2005) [hereinafter ND AUDITOR REPORT], available at http://www.nd.gov/auditor/reports/3023-2_05.pdf.

current limitations of 9-1-1 and expect to have the same service no matter what type of telephone service they use, whether it is wireline, wireless, or [VoIP].”¹²⁰ And third, as noted by Ohio’s Bill Hinkle, many consumers assume that virtually any technology that they utilize will allow them to contact 9-1-1.¹²¹ As noted at the outset of the Article, a high profile example of this is that students attempted to text message 9-1-1 following the Virginia Tech shooting tragedy in spring 2007. Largely due to 9-1-1’s success in telephony, there are expectations that emergency services should be able to handle a wide range of communications technologies, including SMS text messaging, sending pictures via cell phones, and the ability to call from behind private branch exchanges. Of course, as explained in Part II, today’s 9-1-1 systems typically do not meet these expectations.

In short, policymakers must make a choice: either disabuse consumers concerning emergency capabilities, which we do not advise, or commit to provide the services that consumers have come to expect from 9-1-1, which we believe to be the better policy course. All too frequently public safety 9-1-1 capabilities are impoverished compared to the commercial communication networks that increasingly inform consumer expectations concerning communications capabilities. Compared to modern commercial networks, the *status quo* for 9-1-1 systems that use analog emergency networks capable of carrying and receiving only voice traffic is unacceptable.¹²² As detailed above in Part III, the path to an NG9-1-1 system is to view the 9-1-1 system as a common enterprise, i.e., a network of networks, rather than local silos making autonomous decisions. To be sure, there will continue to be an important role for local decision-makers in 9-1-1 services. It is imperative, however, that policymakers recognize that new system designs must be designed *and funded* at higher than local levels in order to realize economies of scale, technical expertise, and purchasing power concerning such networks.

2. Responsible Policymakers Must Have a Viable Funding Strategy for Achieving Next Generation 9-1-1

In the near term, a policymaker’s most urgent challenge is to

120. NGA ISSUE BRIEF, *supra* note 82, at 1 .

121. Telephone Interview with Bill Hinkle, Dir. of Commc’ns, Hamilton County Dep’t of Commc’ns, in Cincinnati, Ohio (Aug. 8, 2007).

122. One individual actively involved in state-level 9-1-1 affairs identified a common attitude toward PSAP equipment as “install it and ignore it.” Moreover, the same official noted that networks and equipment are frequently bundled and the 9-1-1 systems provider will use its ownership position to prevent deployment of a rival network. Additionally, equipment may be subject to multi-year lease arrangements preventing upgrades, and legacy systems have not been upgraded for up to 20 years.

evaluate whether existing funding strategies within his/her respective jurisdiction are sufficient to enable build-out and operation of next generation 9-1-1 services. Indeed, as NENA President Jason Barbour has noted, "Perhaps the most important policy issue today and into the next generation is funding."¹²³

To be sure, this is easier said than done. From a national perspective, the diversity of funding models across jurisdictions means that the sufficiency of funds to support 9-1-1 can only be determined on a jurisdiction-by-jurisdiction basis. Notably, starkly different resources are available in different states and, frequently, between localities within a state. This fragmented approach has made some pessimistic about current models. "[R]elying on the current patchwork 9-1-1 funding model is not sufficient to maintain the current 9-1-1 system, let alone provide for the essential evolution to NG9-1-1."¹²⁴ Moreover, there appear to be wildly divergent visions of what functionalities will constitute next generation 9-1-1, ranging from simple e-mail access to a fully IP-based system. Finally, from the perspective of individuals responsible for a jurisdiction's 9-1-1 services, the emergence of new technologies help "make providing the most efficient E-911 services a constantly moving fiscal target."¹²⁵

For many jurisdictions, often overlooked in considering whether 9-1-1 funding is sufficient is a critical predicate: sufficient for what? Prescient states and localities are taking up the task of answering this question. For example, Indiana's Wireless Advisory Board has led the way in planning and achieving a next generation system which permits packet delivery of wireless calls.¹²⁶ Missouri, which has traditionally lagged in many aspects of 9-1-1 service and reportedly has 21 counties still without even basic 9-1-1 recently commissioned an IP-based system study that carefully examines current 9-1-1 infrastructure in Missouri as well as provides recommendations for a statewide IP-Enabled Network.¹²⁷ Developing an analysis of current capabilities, future needs, and strategies to bridge the two is a critical first step for jurisdictions to complete.

In conjunction with future needs and strategy, our second recommendation focuses on the need for a method to evaluate whether

123. NENA NG9-1-1 FUNDING REPORT, *supra* note 86, at 2.

124. *Id.* at 4.

125. TACIR E-911 STUDY, *supra* note 97, at 72.

126. Telephone Interview with Ken Loudon, Executive Dir., Ind. Enhanced Wireless 911 Bd., in Indianapolis, Ind. (Aug. 2, 2007).

127. See L. ROBERT KIMBALL & ASSOCIATES, RECOMMENDATIONS FOR A MISSOURI STATEWIDE IP-ENABLED NETWORK SUBMITTED TO THE STATE OF MISSOURI (2006) [hereinafter L. ROBERT KIMBALL & ASSOC. MISSOURI RECOMMENDATIONS], available at <http://www.911.oa.mo.gov/pdf/Report2.pdf>.

9-1-1 funding is sufficient. In this respect, we suggest that policymakers evaluate a series of issues. First, they should consider whether the current funding level is sufficient to achieve and support NG9-1-1 systems—with respect to both recurring and non-recurring costs. Second, they should evaluate whether existing funding mechanisms support 9-1-1 services in a manner that fairly matches the expectations, demands, and communications usage patterns of consumers and citizens. Third, they should assess whether existing funding and cost-recovery policies promote vendor and service-provider competition in 9-1-1 services in both pricing and innovation without compromising safety and while minimizing unnecessary market distortions.

In order to transition effectively to an NG9-1-1 system, policymakers cannot be naïve about funding requirements. To be clear, the NG9-1-1 system must be understood as a value proposition, not a cost savings measure. While there may be efficiencies and cost savings involved in an NG9-1-1 system, it is possible—indeed, in the near term, highly likely—that funding requirements for NG9-1-1 system will be greater than current 9-1-1 system costs. Specifically, at least four different types of costs will be required in connection with the move to an NG9-1-1 system: (1) capital expenditures involved in building out a new system; (2) transitional costs, i.e., expenses involved in using the old 9-1-1 system while the new system is phased in; (3) costs of network security and encryption requirements associated with a competitive, IP-based system; and (4) on-going recurring costs of an NG9-1-1 system, which will likely need to account for shorter lifespan of products than traditional network pieces.

The challenge of analyzing the adequacy of available funding strategies involves three steps. First, states need to develop a baseline of existing funding amounts based on the currently used mechanisms in order to “benchmark the existing structure.”¹²⁸ Notably, this step must consider the various funding sources detailed in Section B above, including surcharges, amounts from state and local general funds, grant programs, and other relevant sources. Second, states need to consider the relevant market trends so that they can evaluate the likely changes in current funding sources. Consider, for example, that consumer behavior such as adoption of VoIP telephony services and wireless substitution for wireline services all impact the viability of current funding sources.

And third, policymakers must identify a desired level of service of performance for a next generation system. For example, Massachusetts’ Statewide Emergency Telecommunications Board established technical and operational requirements for PSAPs which in turn helped the state

128. NENA VOIP OID REPORT, *supra* note 89, at 12.

“establish a baseline to determine where resources are needed.”¹²⁹ As detailed in Part II, we believe that the basic architecture to deliver advanced functionalities should be an IP-based next generation system. Such a vision provides a divining factor in determining the costs which must be incurred by PSAPs and by service providers both on a recurring and non-recurring basis in order to reach the prescribed standard of service.

3. The Public Good Nature of 9-1-1 Today Suggests That 9-1-1 Funding Models Should Be Augmented by Financing That Facilitate Capital Expenditures

Consistent with the perspective that 9-1-1 is a “public good,” policymakers should view an NG9-1-1 system as a critical infrastructure which must be valued by the public and supported as such.¹³⁰ One challenge for funding a next generation network, which is generally not addressed by current funding strategies, is the ability to borrow or save funds for future capital upgrades. Stressing that point, another report recently opined, “funding mechanisms must be crafted that allow 9-1-1 administrators to amass a capital reserve for deployment of a new IP based 9-1-1 infrastructure.”¹³¹ Accordingly, state and federal grants, bonds, lines of credit, and other tools should be appropriately considered to support build-out of NG9-1-1 systems.¹³² State recognition of capital

129. NGA ISSUE BRIEF, *supra* note 82, at 6. Similarly, a recent Tennessee study echoed this theme: the “development of standards should provide a means to determine the costs and necessary revenue to provide a minimum level of service statewide.” TACIR E-911 STUDY, *supra* note 97, at 13.

130. Indeed, Executive Order documents have characterized emergency services as “critical infrastructure.” For example, Executive Order No. 13010, 61 Fed. Reg. 37,347 (July 15, 1996), includes emergency services as among the nation’s critical infrastructure. See JOHN MOTEFF & PAUL PARFOMAK, CONG. RESEARCH SERV., CRITICAL INFRASTRUCTURE AND KEY ASSETS: DEFINITION AND IDENTIFICATION (2004), *available at* <http://www.fas.org/sgp/crs/RL32631.pdf>.

131. NENA VOIP OID REPORT, *supra* note 89, at 18.

132. As discussed above, in addition to general sources, funding for our emergency response network relies heavily on surcharges on telephone bills. We do not see this changing in the near future and recognize that, if nothing else, properly managed surcharges provide a dedicated source of funds for 9-1-1. However, reliance on this model in the long term is problematic. As one report put, it the “current financing paradigm for the 9-1-1 system operations will likely prove inadequate in the future.” RESEARCH & INNOVATIVE TECH. ADMIN., U.S. DEPT OF TRANSP., NEXT GENERATION 9-1-1 SYSTEM: PRELIMINARY CONCEPT OF OPERATIONS 6 (2005), *available at* <http://www.its.dot.gov/ng911/pdf/ConOps.pdf>. For example, as two industry participants separately relayed to us, falling rates for telephone service (which some observers view as inevitable) may well lead states to adopt flat fees. To be sure, flat fees do provide greater predictability in the short term, but it is also quite possible that, over the long term, user behavior will continue to change and move toward applications with lower or non-existent 9-1-1 surcharges (say, instant messaging). Moreover, it is unfortunate that the funding source is,

expenditures necessary to support 9-1-1 is not without precedent. For example, New Jersey in 1991 launched a \$94 million lease-purchase agreement program entitled Certificate of Participation (“COP”). The COP program enabled build-out of the State’s original 9-1-1 infrastructure.¹³³ Six years later, in 1997, New Jersey again recognized the need for upgrades and approved a \$4.7 million line of credit.¹³⁴ In short, as evidenced in New Jersey, the model we recommend is one where the state self-consciously suggests strategies for prudent fiscal management that includes a concept of capital expenditures.

Even though local entities should continue to retain control over their 9-1-1 operations, collection of 9-1-1 monies must increasingly occur at the state level in order to facilitate the funding of capital expenditures and the coordination of system build-outs. As emphasized in Part III, achieving an enterprise approach to next generation 9-1-1 systems will require the ability to collect funds at higher level in order to make coordinated network design decisions, capture economies of scale, and realize purchasing power. Moreover, our research found that at least three further reasons militate in favor of this approach. In particular, higher level collection promotes: (1) administrative efficiency by reducing costs related to jurisdictional patchworks for service providers; (2) equitable standards of 9-1-1 services across jurisdictions; and (3) heightened accountability with respect to service provider contributions as well as usage of 9-1-1-related funds. In an environment where an empowered state agency can collect the funds, support localities who are using them, and oversee those localities who do not play by the rules, the level of confidence and effectiveness of the entire system will rise considerably. Of course, the prevention of raiding is also critical to such a system’s efficacy.

in effect, a tax on communications. In general, society should restrict industry specific taxes to behavior it wishes to discourage—say, smoking—and otherwise rely on general revenues (raised from non-distortionary taxes). Consequently, where possible, policymakers should investigate alternatives to a reliance on general taxes.

133. PROFILE OF THE NEW JERSEY E9-1-1 SYSTEM, *supra* note 71.

A COP is a lease-purchase agreement that provides for the acquisition of equipment, services, and real property to be used by various departments and agencies of the state. A COP represents a proportionate interest of the owner thereof in the lease payments to be made by the state under the terms of the lease-purchase agreement.

Id. at n.6.

134. *Id.* at 3. A line of credit makes an amount of money available to a borrower for a specified duration of time.

4. Greater Oversight Should Be Used to Monitor Fund Collection, Deter 9-1-1 Funding Raids, and Ensure That 9-1-1 Purchases Reflect Sound Judgment

In many cases, the system of 9-1-1 funding has operated on “autopilot” with too little planning and oversight of the relevant players. Raiding continues to be a significant problem for 9-1-1 funding. And either to avoid the blatant fund sweeps or the possible threat of cutting funding levels, some jurisdictions continue to use 9-1-1 funds for other purposes. There is, of course, an irony here: the threat of state raiding 9-1-1 funds encourages unproductive behavior on the local level. And, to top it off, there are incidents where carriers—perhaps believing that the system has sufficient funding, perhaps just on account of sloppy accounting, or even reflecting efforts to cheat the fund—fail to collect and remit the requisite amount.

We found that misallocation and misuse of 9-1-1 funds present important funding challenges for most jurisdictions. Aside from these problems, the majority of individuals interviewed as well as the majority of publicly available state reports suggest that current funding models appear generally sufficient to sustain the *status quo* of their 9-1-1 systems. To be sure, this is very much a case-by-case determination specific to individual jurisdictions and we found several areas in which funding is regularly insufficient to maintain existing levels of 9-1-1 service. In particular, areas which rely heavily on wireline surcharges are experiencing difficulty as wireless and VoIP substitution results in lower wireline revenues. Additionally, rural areas with smaller fee bases commonly struggle and, in the absence of grant programs or outside assistance, rural localities often lag in E9-1-1 service. Finally, high call volume in areas where mobile traffic is frequent—such as along interstates and in tourist destinations populated by out-of-state residents—often burdens a jurisdiction’s 9-1-1 services. This reflects that mobile telephony is problematic for existing surcharge models: mobility partitions the location from which a call is made from the address where a surcharge is collected. This is important for high-mobile call volume jurisdictions because traditional surcharge models do not provide for contributions from 9-1-1 callers who live outside their jurisdiction.

Significantly, we find that more must be done to insert safeguards into the 9-1-1 funding system to improved vigilance against (1) under collection of funds and (2) misuse of funds. We address each issue in turn.

Not surprisingly, administration of surcharge payments into the 9-1-1 system is more complicated today than during the monopoly era when fewer players and technologies were involved. Today, given the

proliferation of telecommunications services and an expanding range of players, tracking collection of 9-1-1 surcharge payments presents a growing challenge. Of course, the fragmented nature of local collection compounds the difficulty of ascertaining the relevant funding levels. For example, in our interviews one state official reported that his state formed a committee which approved a CPA firm to collect information on wireline revenues collected by counties, but only half of the state's counties responded. Overall, jurisdictions must address the challenge of tracking funds in order to ensure a level competitive playing field for providers as well as ensuring that the 9-1-1 system receives the funding which policymakers intended.

A 2007 audit in Oregon underscores the lack of controls currently in place. In that case, the auditors found that revenue officials simply did not have a proper process to verify whether telephone providers paid 9-1-1 amounts due. In particular, the audit estimated that as a consequence Oregon may have failed and continues to fail to collect as much as \$4 million per year in amounts due from telephone carriers.¹³⁵ Notably, the audit indicated that the problem is not limited to Oregon: "The issue of 9-1-1 revenue reporting and remittance is receiving increased attention nationwide. For example, officials from . . . [several states] expressed concern regarding the accuracy and completeness of the 9-1-1 revenue collected in their states."¹³⁶

As the Oregon report suggests, other states have similar problems. In North Dakota, for example, the state has had difficulty monitoring telecommunications providers who withheld excess administrative costs and, as a result, underpaid 9-1-1 fees at the remittance stage.¹³⁷ Moreover, a New Hampshire performance audit determined that the State's Bureau of Emergency Communications ("BEC"), which performs a critical role in the State's 9-1-1 system, is deficient in "collection and tracking of surcharge payments."¹³⁸ In particular, the New Hampshire audit identified three recommendations. First, the State should require that companies use a standardized reporting document to be submitted with monthly surcharge payments. This would allow the State to better identify companies using an improper methodology in calculating surcharge amounts. Second, the State should consistently track payments from companies because, under the BEC's approach, it could

135. *Oregon 9-1-1 Phone Tax Payments Fall Short*, ARGUS OBSERVER, Sept. 27, 2007, available at <http://www.argusobserver.com/articles/2007/09/27/news/07.txt>.

136. OR. SEC'Y OF STATE, OREGON DEPARTMENT OF REVENUE: 9-1-1 TAX REVIEW 4 (2007), available at <http://www.sos.state.or.us/audits/reports/full/2007/2007-23.pdf>. The audit specifically cited similar concerns from officials in Delaware, New York, Minnesota, and Arizona. *Id.* at 4-5.

137. ND AUDITOR REPORT, *supra* note 119, at 18.

138. N.H. PERFORMANCE AUDIT REPORT, *supra* note 43.

“not be certain for which months companies have or have not submitted surcharge payments.”¹³⁹ Third, where companies fail to make proper surcharge contributions, there must be enforcement capabilities. For example, two companies went a year without making payments and, without an enforcement mechanism such as late fees or penalties, this can be seen as a rational strategy because “there is little incentive for companies to submit timely payments.”¹⁴⁰

In addition to ensuring that proper contributions are made in connection with the collection and remittance stages, it is important to guard against misuse of funds at the usage stage. Notably, we found a number of strategies available to policymakers to guard against misuse of funds problems. One strategy involves development of a unified system of reporting and accounting for review of local expenditures. For example, Tennessee has adopted a uniform financial accounting system developed by the Comptroller of the Treasury that local Emergency Communications Districts use in connection with annual reports.¹⁴¹ The accounting system’s review is backed by meaningful consequences: if local districts are found in violation of state law or not acting in good faith, wireless distributions may be withheld.¹⁴²

A second strategy involves providing greater guidance concerning usage of funds. At least in writing, most jurisdictions have criteria setting forth how 9-1-1 funds may be used.¹⁴³ Such guidelines have varying levels of specificity, ranging from the vague to highly prescriptive. Guidelines also vary concerning the scope of what may be used with 9-1-1 funds and some guidelines are clearly wanting. In North Dakota, for example, a state audit found “a lack of adequate guidance provided to political subdivisions on what 911 fees are to be used for or what they should not be used for. Improvements are needed to ensure that the use of 911 fees comply with legislative intent.”¹⁴⁴ In contrast, Montana today sets forth *Basic and Enhanced 9-1-1 Funding Guidelines* that determine budget items eligible for funding.¹⁴⁵

Written guidelines such as Montana’s are valuable insofar as they provide clear guidance and transparency concerning how 9-1-1 funds are

139. *Id.* at 29.

140. *Id.* at 30.

141. TACIRE-911 STUDY, *supra* note 97, at 25.

142. *Id.*

143. GAO STATES’ COLLECTION REPORT, *supra* note 54, at 16 (noting that 35 jurisdictions out of 44 responding claimed to have written policies governing use of 9-1-1 funds).

144. ND AUDITOR REPORT, *supra* note 119, at 11.

145. STATE OF MONTANA, BASIC AND ENHANCED 9-1-1 FUNDING GUIDELINES (2006), *available* [at http://itsd.mt.gov/techmt/publicsafety/911_Funding_Guideines_Oct_06.doc](http://itsd.mt.gov/techmt/publicsafety/911_Funding_Guideines_Oct_06.doc).

allocated and used. In Montana's case, they specify a series of categories that are eligible for support through E9-1-1 funds.¹⁴⁶ First, they support PSAP Operation, such the telephone system for the PSAP capable of handling required 9-1-1 trunks and non-emergency lines, the installation and recurring costs for 9-1-1 trunks and non-emergency lines, radio frequency coordination, software and hardware for computer aided dispatch ("CAD"), computer hardware and software used by call takers and/or radio dispatchers, and PSAP's share of records management system ("RMS") software. Second, they call for support for E9-1-1 related budget items for development, installation, and operation of the E9-1-1 system, such as, among other things, telephone equipment which can handle and display E9-1-1 database information, costs to develop and maintain the Master Street Address Guide ("MSAG") and E9-1-1 database, project manager costs, and costs associated with providing wireless E9-1-1 services. Third, they authorize support for dispatch related budget items to enable dispatch, relay, or transfer of calls for emergency service. Finally, they allow the funds to be used for other justifiable costs, including training for PSAP telecommunicators, PSAP building requirements, public education, salaries, and addressing.

In addition to restrictions on permitted uses of funds, another notable type of guidance strategy includes offering assistance concerning what funds should be used for. "Many states and national organizations provide education and outreach to PSAPs to help them identify their equipment upgrade needs."¹⁴⁷ Several jurisdictions offer technical consulting to assist selection of what should be purchased with funds. For example, Washington offers technical assistance concerning equipment and system integration.¹⁴⁸ Virginia supports PSAPs project management, consulting, and training.¹⁴⁹ Overall, such technical assistance which helps train and provide expertise is important. In New Mexico, for example, an after-action report studied lessons learned in connection with achieving state-wide addressing for E9-1-1.¹⁵⁰ Despite a state grant providing for purchase of technology solutions, the report noted the disparity of local project manager skills and determined that geographic information systems "were not solutions. Instead, reliable

146. *Id.*

147. NGA ISSUE BRIEF, *supra* note 82, at 7.

148. *Id.*

149. *Id.*

150. DAVID HANNA, ASSISTANT DIR. LOCAL GOV'T DIV., N.M. DEP'T OF FIN. & ADMIN., STATEWIDE ADDRESSING FOR ENHANCED 9-1-1: LESSONS LEARNED IN NEW MEXICO 3-4 (2003), *available at* <http://spb.nmdfa.state.nm.us/cms/kunde/rts/spbnmdfastatenmus/docs/202744167-06-28-2006-12-36-14.pdf>.

people trained to use the technology were the solution.”¹⁵¹

5. 9-1-1 Surcharges Should Be Assessed in a Principled Manner That Promotes Competition

Irrespective of method of calculation, an additional finding of our research concerns how jurisdictions determine the amount of a surcharge. For example, it is fair to ask why a particular jurisdiction’s VoIP surcharge is \$.75 instead of, say, \$1.25 or just \$.25. Our research indicates that many surcharge amounts, especially relating to wireless and VoIP amounts, are the result of political compromise and wild guesswork. This certainly does not need to be the case. A jurisdiction could instead assess surcharges based on a variety of principles, including how much cost a user or service imposes upon the overall 9-1-1 system, on the basis of technology neutrality (i.e., ensure that wireline, wireless, and VoIP charges are the same), or perhaps on the basis of what is needed in the way of overall 9-1-1 funding.

Our research did not find that these or other principled approaches prevailed in anchoring many 9-1-1 surcharge determinations. Indeed, as one official reported, the relevant charges were often the results of political compromise or just “pulled out of thin air.” Unfortunately, where surcharge amounts reflect guesswork and political compromise, they needlessly distort competitive forces. Accordingly, in connection with the migration to an NG9-1-1 world, we recommend that surcharges be informed by a policy of equity and then parity. That is, to the extent that a particular service—say, wireless phones—imposes unique costs upon the 9-1-1 system, equity dictates that that particular service should pay for the respective cost it imposes on the system. Once a call reaches the part of the 9-1-1 system where unique costs are no longer imposed, however, parity dictates that different services should pay the same amount to fund such common costs. In this manner, we believe that a principled approach to 9-1-1 will reduce unnecessary market distortions and introduce greater fairness into the system.

CONCLUSION

Our current system of emergency communications has failed to keep pace with technology and does little more than its original aspiration—providing a single number to contact emergency services. This is an admittedly valuable service and our 9-1-1 system has most certainly saved lives and protected property using this system for almost forty years. It has not, however, evolved effectively as technological

151. *Id.*

change—particularly related to the transition from analog to digital, fixed to mobile, and narrowband (voice-optimized) to broadband (data-optimized) communications—has transformed our system of telecommunications.

The opportunity to upgrade our system of 9-1-1 communications is not merely a compelling opportunity. It is a national imperative. As we have emphasized, the public generally expects to be able to reach 9-1-1 using an array of modern technologies, from the ability to email pictures using mobile phones to VoIP technologies to text messaging. As a technical matter, it is not difficult to upgrade the 9-1-1 system in such a manner, making it not only more effective but also more efficient and reliable. The key question, therefore, is when policymakers will enact the necessary reforms in governance and funding to make that transition possible. Given the powerful case for this transition, and widespread awareness of the need to make it,¹⁵² there is little reason to delay.

152. As one survey of state administrators reports: "They understand that they must do this now or face the prospect of having a 9-1-1 system that is essentially broken, unable to handle calls from communications technologies that the public is already using, not to mention future technologies." L. ROBERT KIMBALL & ASSOC. MISSOURI RECOMMENDATIONS, *supra* note 127, at 2.